

GLADEVILLE UTILITY DISTRICT GLADEVILLE, TENNESSEE



STANDARD WATER SPECIFICATIONS

May 2026

Eric Broomfield, PE
General Manager

Approved by:

DW20260263

APPROVED WATER SPECIFICATIONS

THE DOCUMENT BEARING THIS STAMP HAS BEEN RECEIVED AND REVIEWED BY THE

TENNESSEE DEPT. OF ENVIRONMENT & CONSERVATION

DIVISION OF WATER RESOURCES

AND IS HEREBY APPROVED FOR USE IN CONSTRUCTION BY THE COMMISSIONER

05/21/2026

THIS APPROVAL SHALL NOT BE CONSTRUED AS CREATING A
PRESUMPTION OF CORRECT OPERATION OR AS WARRANTING BY THE
COMMISSIONER THAT THE APPROVED FACILITIES WILL REACH THE
DESIGNED GOALS.

APPROVAL EXPIRES FIVE YEARS FROM ABOVE DATE



**GLADEVILLE UTILITY DISTRICT
STANDARD SPECIFICATIONS & DESIGN CRITERIA
TABLE OF CONTENTS**

- 1.0 Design Criteria and Technical Requirements
 - 1.01 Applicability
 - 1.02 Definitions
 - 1.03 Technical Requirements
 - 1.04 Design Criteria
 - 1.05 Easements

- 2.0 General Construction Requirements
 - 2.01 General Project Requirements
 - 2.02 Not Used
 - 2.03 Field Engineering
 - 2.04 Project Coordination and Access
 - 2.05 Shop Drawings & Product Data
 - 2.06 Temporary Controls
 - 2.07 Transportation and Handling
 - 2.08 Storage and Protection
 - 2.09 Project Closeouts
 - 2.10 Project Record Documents
 - 2.11 Cleaning
 - 2.12 Trenching, Backfilling & Compaction for Utilities
 - 2.13 Unclassified Excavation for Utilities
 - 2.14 Erosion Control
 - 2.15 Finish Grading
 - 2.16 Seeding
 - 2.17 Boring and Casing for Water Lines

- 3.0 Technical Specifications - Water Lines
 - 3.01 Water Lines
 - 3.02 Water Valves, Hydrants and Appurtenances
 - 3.03 Water Service Assemblies

- 4.0 Technical Specifications - Concrete
 - 4.01 Concrete for Utility Lines

- 5.0 Standard Construction Details

SECTION 1.00

DESIGN CRITERIA AND TECHNICAL REQUIREMENTS

SECTION 1 - PROJECT DEVELOPMENT AND GUIDELINES

1.01 APPLICABILITY

- A. These Specifications shall apply to the construction of water lines and other water distribution facilities which are located within the boundaries of the **Gladeville Utility District of Wilson County, Tennessee**.
- B. The **CONTRACTOR/DEVELOPER** shall be responsible for the furnishing of all materials (unless materials are to be supplied by **Gladeville Utility District** under separate agreement), machinery, labor, equipment and services necessary for the construction of water supply and distribution facilities in accordance with these Specifications and as shown on Plans prepared by or on behalf of the **District**.
- C. These Specifications set forth the standards for the materials used in the water distribution system and the requirements for their installation and construction. The requirements include all necessary construction work items from clearing, staking, excavating, bedding, water line laying, backfilling, grading, clean-up, erosion control and restoration to property, testing and disinfection, etc., for the proper and complete installation of the facilities that comprise the water distribution system.

1.02 DEFINITIONS

- A. **AUTHORITY HAVING JURISDICTION (AHJ)** – The authority who has overall review and approval of the proposed development (Wilson County, TN or City of Lebanon, TN).
APPLICANT – The person or entity seeking water service from the Gladeville Utility District.
- B. **BOARD** – The governing Board of Commissioners for the Gladeville Utility District consisting of three voting members.
- C. **CONTRACTOR** – The Contractor shall be the installer of water system additions and shall be under the employ of the Developer for a site. The Contractor shall be a properly licensed Contractor in the State of Tennessee, having the appropriate license classification to cover the work to be performed.

- D. **DEVELOPER** – The person on entity owning and developing a new site or property within the service area of the Gladeville Utility District.
- E. **DISTRICT** – The **Gladeville Utility District** providing water service to portions of Wilson, Davidson and Rutherford Counties as and defined by record with the Tennessee State Legislature and/or the Register’s Office of the Counties listed above..
- F. **DISTRICT ENGINEER** – The engineer of record for the District water improvements. The District Engineer is selected by and serves at the direction of the District’s General Manager.
- G. **DISTRICT PLANS** – Plans developed by the District or by the District Engineer for all District water improvements.
- H. **GENERAL MANAGER** – The General Manager for the District who directs all day-to-day operations of the District.
- I. **OWNER** – See DISTRICT.
- J. **PLAT** – Document showing general layout of all property lines, rights-of-way, easements, utilities, encumbrances, ownership, map and parcel information.
- K. **SITE ENGINEER** – Engineer of record for the site development and working for the Developer.
- L. **SITE PLANS** – Plans developed by the Site Engineer showing all improvements to a new development at the direction of the Developer.
- M. **STATE** – The State of Tennessee, Division of Water Resources

1.03 TECHNICAL REQUIREMENTS - These technical requirements are provided as a guide to **Developers, Site Engineers** and **Contractors** to the requirements of the **District** in the review and approval of Plans for construction of public water line extensions and related appurtenances including Final Plats and easement documents. For procedural requirements and fees relating to water service for new development, refer to the District’s website.

- A. For initial submittal requesting Letters of Availability, the Site Engineer must complete and submit a Request for Water Service Application to the **District** for review and evaluation.
- B. The **District** or the **District’s Engineer** shall prepare plans for all **District** improvements including but not limited to water line extensions, meter pits,

- easements (lines and meters) and the applicable permit from the Tennessee Department of Environment and Conservation, Division of Water Resources related to the installation of the proposed water system improvements. Fee applicable to each development shall be calculated in accordance with the District's Development Policy and Fee Schedule. The Site Engineer and/or Developer should contact the **Gladeville Utility District** to determine the scope of each improvement and the associated fees that will accompany the proposed improvement. No design of any improvement will begin until such fees have been paid to the **Gladeville Utility District**. If design changes are required due to development requirements and the design has been completed and approved by the State, re-design efforts for these changes will require additional fees. Such re-design changes and design fees would be on a case-by-case basis and would be determined by the General Manager and the **District Engineer** for the proposed changes.
- C. No work will occur on the design documents until the applicable fees have been received by the **District**. Upon receipt of the applicable fees, the **District** will proceed or authorize the **District Engineer** to proceed with the design preparation of the public water system improvements. Once the design preparation has been authorized, the **Developer** shall authorize his site engineer to provide the **District and the District Engineer** with appropriate electronic files on which to prepare the public water improvements.
- D. At a minimum, the **Site Engineer** shall provide the following information in electronic CAD files to the **District and the District Engineer** for development of the water system improvements:
1. All topographic features of existing and proposed improvements including but not limited to roadways, storm drainage pipe and appurtenances, driveways, trees to be preserved, all existing and proposed utilities including sanitary sewer, gas, electric, telephone, cable television.
 2. Rights of ways (existing and proposed); property or lot lines with map and parcel numbers, lot line boundary calls; property ownership; deed book and page; all existing and proposed easements.
 3. The desired water line layout including approximate location of proposed fire hydrants and proposed meter locations.
 4. Special items such as stream crossings.
 5. Proposed site buildings; driveways, parking spaces, landscape islands, etc.
 6. Roadway layouts and roadway profiles where applicable.
 7. Grading plans (existing and proposed)

8. Onsite sanitary sewer including septic tanks, gas lines, storm sewers and drainage structures and detention devices, box culverts, electrical, irrigation, geothermal or other plans which might conflict with water line design and installation.
 9. Landscape and planting plans.
 10. Any other site features that might impact the placement of proposed water lines and appurtenances.
 11. Electronic CAD files shall be in AutoCAD or MicroStation format.
- E. Water lines are to be located within exclusive easements dedicated to the **Gladeville Utility District. (See Section 1.05 – Easements) unless otherwise approved by the District or located within public right-of-ways.** The water lines should be generally located as follows unless unusual conditions, which will require special conditions, make it impractical to do so. Proposed water lines are to be located within an exclusive 20-foot **District** easement unless otherwise approved by the **District**. The water line may be located a minimum of 5 feet from the right-of-way or sidewalk, if sidewalks are provided. Water lines shall not be located under pavement of public or private roadways except where crossings occur. Longitudinal placement of water lines in roadways (public or private) will not be permitted. Where water lines are located in paved parking areas, they shall not be located beneath parking spaces in a longitudinal manner. Where water lines are located in parking areas, they shall be centered in the lane between parking spaces. Where water lines are to cross perpendicular to parking areas, they shall be placed in such a manner to impact the least number of parking spaces. No water appurtenances such as valves, hydrants or meters shall be located within parking spaces or sidewalks. Meters shall be located in green space area. Water meters shall not be located in paved roadways, driveways, or parking areas
- F. Upon completion of the design of the proposed water improvements, the **District or the District Engineer** shall provide a copy of the proposed design to the **Site Engineer** to check to ensure that overall intent of site design is met and conflicts have been avoided.
- G. Once design has been approved by the **Site Engineer**, the design will be signed by the **District** and submitted to the State for approval by the **District or District Engineer**. State approved plans will be returned to the **District** and the **District** will issue State approved plans to the Developer after payment of all fees and execution of all **District** requirements.
- H. Once a design is complete and has received approval for the State of Tennessee, any changes required to the design documents as a result of changes brought about by the **Applicant** or **Developer** may result in additional design fees to the

District. In these cases, the **Applicant, Developer** or **Site Engineer** shall contact the **General Manager** for additional design fees that may be required.

- I. The **Developer/Site Engineer** is responsible for obtaining all necessary approvals from all applicable jurisdictional agencies including but not limited to: Wilson, Davidson or Rutherford County; City of Lebanon; Tennessee Department of Environment and Conservation, Division of Water Pollution Control; Tennessee Department of Transportation; Corps of Engineers; and the Tennessee Valley Authority that are required as a result of **District** water improvements. The **District** will obtain the TDEC, Division of Water Resources approval based upon the design documents prepared by the **District or District Engineer**. The **District** will not obtain permits from other agencies for proposed water improvements, unless otherwise agreed to by the **District**.
- J. For commercial and residential fire sprinkler applications, the **Developer** or his **Site Engineer** is responsible for coordination with the applicable Fire Marshall for determination of required fire flows.
- K. Residential Fire Sprinkler Applications
 1. If the AHJ requires residential fire sprinkler systems, it will be the Developer/Home Builder's responsibility to design and size all components associated with a residential fire sprinkler system including meter and tap size.
 2. The Developer/Home Builder's fire sprinkler engineer shall acknowledge in writing to the **District**, that all residential fire service assemblies are adequately sized to accommodate the required fire sprinkler flow and pressure requirements for the development in accordance with NFPA 13D or the AHJ having jurisdiction.
 3. The **District DOES NOT** guarantee any flow or pressure minimums with regard to fire hydrants or fire sprinkler systems.
 4. The **District** assumes no responsibility for ensuring that the installation of residential fire sprinkler systems complies with any codes, regulations, or standards other than those of the District. It shall be the Developer/Home Builder's sole responsibility to comply with all applicable rules and laws.
 5. Residential dwellings requiring a residential fire sprinkler system must have a passive purge/flow-through sprinkler system installed.
 7. Before the **District** will install the meter for the residential dwelling, documentation from the governing AHJ fire marshal must be provided to the **District** stating an inspection was made verifying the passive

purge/flow-through sprinkler system was appropriately installed.

8. Water meters required for residential fire sprinkler applications shall be a Badger™ brand meter of sufficient size to meet the fire sprinkler system flow requirement.

L. Where development requires new public water lines to be extended into a site or parcel for water service and where contiguous property is available outside the boundary of the site or parcel being served that is within the **District** service area, the **District** may require extension of new public water lines to all boundaries of the site or parcel being developed in order to allow for continuation of future water service. Dedication of easement to accommodate these extensions will also be required.

M. Design of **District** improvements shall cease at the meter pit and does not include onsite water or fire lines, pressure reducing valves, or backflow prevention devices. All design of onsite water improvements will remain the responsibility of the **Developer and Site Engineer**. Preparation of the final plat shall also remain the responsibility of the **Developer**. Preparation of water easements related to new **District** water lines and appurtenances will be prepared by the **District or the District Engineer**. The **Developer** will be charged with execution of the easement for proposed water improvements.

N. Each parcel shall be independently metered for fire, domestic and irrigation water service. No sharing of meters will be permitted between parcels where multiple parcels are involved. Where two or more small commercial buildings (< 7,000 SF) are contained on one parcel, domestic metering will be required for each building. Fire flow metering may be shared if the two buildings are in close proximity and will be considered on a case-by-case basis with the **District**. Irrigation metering may be shared where two or more buildings are contained on one parcel. Where large buildings such as multi-story offices, hotels or other high exposure fire demands exist on one parcel, each shall be independently metered for fire flows. Where the circumstance arises that one parcel already has water service and internal water supply piping and a second parcel is created (outparcel), then new meter connections for the outparcel will be required from an existing public water line. New meter connections from an existing private water line will not be permitted.

O. Refer to the **District** Cross-Connection Control Plan for requirements related to location and types of backflow prevention devices. Such devices and their locations are subject to approval by the **District** but they are not and will not become a part of the Gladeville Water System.

1.04 DESIGN CRITERIA - The following design guidelines for the preparation of water service and water line extension plans constitute the minimum requirements of the **District**. **The District reserves the right, at its option, to impose requirements above**

the minimum standards set forth herein.

- A. In all development applications, the **Developer** or the **Site Engineer** will be required to submit water demand information for domestic, fire and irrigation demands to assist in the proper sizing of water lines and appurtenances.
- B. Where underground electrical lines exist or are proposed, the water line shall be located on the opposite side of the roadway. In commercial developments, the minimum separation between underground electrical and proposed water lines shall be 10' horizontal separation. Vertical separation shall be 18 inches.
- C. Where gas lines exist or are proposed, a minimum 10' horizontal separation between the water line and gas line must be maintained. Vertical separation shall be 18 inches. Where gas lines are steel, the new ductile iron water line shall be poly-wrapped for a length of 10-feet either side of a crossing or if parallel, poly-wrap the entire length of the water line.
- D. Where sanitary sewerage lines including STEP tanks exist or are proposed, a minimum 10' horizontal separation must be maintained with the water line. At crossing points, a minimum 18" vertical separation must be maintained with the water line at the higher elevation. (See Section 3.01.Water Lines Paragraph 3.04 – Installation of Water Lines).
- E. Where storm drainage lines exist or are proposed, a minimum 10' horizontal separation must be maintained with the water line. At crossing points, a minimum 18" vertical separation must be maintained with the water line at the higher elevation. (See Section 3.01.Water Lines Paragraph 3.04 – Installation of Water Lines).
- F. ~~Water lines shall be located a minimum of 36 inches below the lower of: the proposed grade over the water line or if driveways are anticipated, below the grade line of the roadway at the edge of pavement.~~ Water lines in easement areas shall have a minimum of 36 inches of cover. In driveways or roadway crossings in industrial/commercial areas, the water line cover shall be 42 inch minimum. In residential developments, driveway and roadway crossings shall maintain a minimum of 36 inches of cover.
- G. Maximum proposed grading across the **District** easement shall be limited to 5 Horizontal to 1 Vertical (5H:1V). If 5H:1V cannot be maintained within water service meter locations, retaining walls may be utilized to create areas suitable for meter pit installations.
- H. Minimum water line size is 8" except that 6" water lines may be used on short dead end sections not exceeding 300 feet in length or on looped sections not exceeding 800 feet in length subject to the approval of the **District**. 1" through 4" diameter water lines are only permitted for meter service connections.

- I. Restrained joint systems for water line installations shall be designed using the Ductile Iron Pipe Research Association (DIPRA) or EBAA™ joint restraint calculation equations. Soil conditions and bedding types shall be based on each specific location of the water line. Design pressure shall be for 200 psi with a safety factor of 1.5. Restrained joint piping may be considered in locations where poor soil conditions exist which would impact the ability of concrete kickers to be effective OR in locations where extreme vertical alignment changes are required OR where proximity to other utilities limits the space available to install kickers or transfer loads to other utilities. Restrained joint piping will be noted on the design plans where applicable.

- J. Fire hydrants shall be installed at the ends of 6-inch and larger dead end water mains. On phased developments, a fire hydrant assembly including isolation valve and two (2) line valves shall be placed to facilitate future line extension. Blow-off assemblies at ends of 4-inch water lines will be considered for special situations. All fire hydrants shall be installed with isolation valves. Isolation valves shall be connected to a hydrant tee on the inlet side of the valve and to a 6-inch by 24 inch long hydrant coupling on the outlet side of the valve. Fire hydrant spacing must be approved by the **AHJ** as well as by the **District**. Fire flow and fire hydrant pressure requirements shall meet the requirements of the **AHJ**. The **District** will require one (1) public fire hydrant at each industrial/commercial meter location. All private fire lines must be metered and appropriate backflow devices are required. All public fire hydrants must be painted factory-painted yellow. Hydrants shall be purchased by the **Contractor** in the appropriate color so re-painting of hydrant body is not required. Bonnets will be color coded in accordance with NFPA 291. Color coding will be as directed by the District or the District Engineer at the time of the shop drawing submittals and the hydrants shall be furnished pre-painted in the appropriate flow color coding. Private fire hydrants inside developments and behind the fire meter shall be painted white or silver.

- K. Water valves shall be provided at a maximum spacing of 1000 feet along a water main and on all lines at intersection nodes. All water meters inside commercial and industrial development shall be served by independent valve so that any meter can be isolated without impact to other meter services. The valves are to be located within the **District** easement. All public water valve boxes are to be painted blue. All private water valve boxes are to be painted white or silver.

- L. A Post Indicator Valve will be required on fire service meters and meters 3 inches and larger on the meter bypass line. The post indicator shall be provided with factory applied blue color.

- M. Automatic air release valves or fire hydrant assemblies should be provided at all high and low points along the water line as directed by the **District**.

- N. Due to the varied elevations across the **District**, pressures may exceed 160 psi in

some locations. Where such high pressures exist, it is **highly recommended** that **Site Engineers, Developers** and property owners confirm the system pressure at their meter location and install a **privately owned** pressure reducing valve to protect their internal water system. Customer pressure reducing valves should be installed as recommended by the Standard Plumbing Code and should be installed in locations immediately behind the meter or the backflow prevention device. These devices are not part of the public water system.

- O. When water extensions are proposed in new developments, the **Master Plans** and/or **Preliminary Plats** as approved by the Wilson, Davidson or Rutherford County Planning Commission, the City of Lebanon, as applicable, are to be provided to the **District** for review and approval.
- P. All domestic service connection in newly developed single lot residential areas will be a 5/8" x 3/4" meter. For residential homes that require a fire sprinkler system, meters shall be full sized 3/4 inch. Fire, domestic and irrigation service connections for commercial, retail, apartments, multi-family and other developments shall each be sized for their specific water demands and as noted on the **District** approved plans.
- Q. Commercial Meter and Fire Meter Sizing – The **District** does not size the large diameter meters for commercial or fire service meters. As part of the Developer’s Agreement Application, the **Developer’s Site Engineer** shall provide the flow requirements for the development as well as the proposed meter sizes. It is highly recommended that the **Engineer** review AWWA Manual M22 – “Sizing Water Service Lines and Meters” to determine meter sizing.
- R. Steel casing pipe shall be provided for water line crossings under all arterial and collector roads. Casing pipe beneath commercial driveway ramps and other high traffic areas shall be as determined by the **District**. All carrier pipe inside cased crossings shall be restrained joint pipe utilizing grip ring gaskets and be installed using casing spacers and casing end seals.
- S. The posting of a performance bond with the **District** in the amount of 100% of the estimated construction cost of the proposed improvements will be required prior to the start of construction of any public water system improvements. The **District or the District Engineer** will prepare the cost estimate for bond purposes.
- T. All water system improvements will require the posting of a performance bond with the **District** in the amount of 100% of the estimated construction cost of the proposed improvements. The **District or the District Engineer** will prepare the cost estimate for bond purposes. The performance bond shall be in place prior to the pre-construction meeting.
- U. Unless otherwise agreed to by the **District**, Special permits related to proposed

- water improvements for: T.V.A. crossings; State of Tennessee and/or Corps of Engineers stream crossings; erosion control permits and State Highway crossings must be prepared by the **Site Engineer**. The **District Engineer** will not prepare special permits for the proposed water line improvements and the **District** will not obtain the special permits. In the case of railroad or State highway crossings which require permitting in perpetuity, the **District** will sign and maintain the permit with the governing agency.
- V. Permits for pavement cuts or crossing of public roads, including any special backfill and pavement repair or work in the right-of-way as required by the **AHJ**, are the responsibility of the **Developer/Contractor**. Water line installation shall not proceed until **Developer/Contractor** has provided proof of such regulatory permits to the **District**.
 - W. Backfill of water lines proposed either in or adjacent to an existing or proposed road must meet the requirements of the **AHJ** over that road. Refer to Section 3.01 – Water Lines for backfill requirements.
 - X. The **Developer/Site Engineer** is responsible for coordinating the approval of any Plan for road/driveway construction or site grading that is proposed over an existing **District** water line. The **Applicant** shall request that the **District** locate the existing water line. Vertical depth confirmation shall be undertaken by the **DISTRICT** and provided to the **Developer/Site Engineer**. The location and depth are then to be delineated on the Plan submitted to the **District**. Depth of cover over existing water lines shall not be less than 36 inches or greater than 60 inches. Depth of cover in excess of 60 inches up to 96 inches will be reviewed on a case-by-case basis by the **District**. Locations where depth of cover will be less than 36 inches or exceed 96 inches will require relocation of the existing water line to a location where depths are at least 36 inches or does not exceed 60 inches.
 - Y. If construction has not started within one year from the date of approval, complete water line plans must be re-submitted to the **District** and **Tennessee Department of Environment and Conservation** and the **Tennessee Department of Transportation** in order to re-new the approval. **State** approved water line plans shall be onsite at all times during water line construction activities.
 - Z. Landscaping inside water meter service easement shall be limited to small shrubbery (no larger than 30 inches). No tress or other large shrubs shall be placed inside the exclusive meter area. Additionally, no trees or shrubbery may be planted within three (3) feet of any meter vault or any valve box. In water main distribution easements, no trees will be permitted on the exclusive easement. Shrubby is permitted within water main distribution easements but shall not be installed directly over the water line and shall be limited to 30 inches in height. If shrubbery grows greater than 30 inches in height, the **District** will not be responsible for replacement if damaged during maintenance/repair of any water

infrastructure.

- AA. All fences, mailboxes, landscape retaining walls, etc. are to be located a minimum of five (5) feet away from water mains, meter boxes, valve boxes and any other public water infrastructure. If this minimum distance is not met, the **District** will not be responsible for the repair or replacement of the aforementioned items during maintenance/repair of any water infrastructure.
- BB. Final punch list completion and approval and acceptance of completed improvements by the **General Manager** must be completed prior to the release of the performance bond.
- CC. One month prior to the end of the maintenance bond expiration, the **DISTRICT** will conduct a warranty review of the water appurtenances and notify the **Developer** of any deficiencies and the **Developer** is responsible for correction of same.
- DD. Upon completion of public water system improvements, the **Developer** will deed the new water improvements to the **District** and will be required to post a maintenance bond in the amount of 25% of the performance bond amount. Maintenance bond will remain in force for 365 calendar days from the date of final acceptance of improvements by the **General Manager**.

1.05 EASEMENTS

- A. The **District** requires that water mains be located within exclusive water line easements. A 20 foot wide water line easement (unless otherwise approved) is to be provided for all new water line extensions. All combined water meter installations (Domestic/fire or Domestic/fire/irrigation) require a minimum 15' x 15' exclusive meter vault easement to be dedicated to the **District**. Larger meter easements may be required if site conditions dictate. **District** water line easements may cross other existing utility easements with approval of the entity holding the easement and may cross previously platted utility and drainage easements.
- B. Easements for water line extensions and/or meter vaults are to be prepared as follows:
 - 1. Easement Documents are to be prepared by the **District Engineer** using information provided by the **Site Engineer** and executed by the **Developer**. These documents include: the District's standard easement and a legal description of the easement by metes and bounds with an exhibit map on the **District's Exhibit Map** form to a scale that is suitable for recording. A copy of the **District's Exclusive Easement Form** is available at the **District** office. Easement exhibits shall include a north arrow, scale, line tables, curve data tables, point of commencement and

- point of beginning of each easement, and name of entity which prepared the easement document.
2. A separate easement document shall be generated for each separate property that the easement will impact. Separate easement exhibits will be provided for different easements on the same property.
 3. The water line easements are to be delineated on the Water Line Plans and are to be set to record in the Registrar's Office of Wilson County prior to the pre-construction conference with the **District**.
 4. The water line easements shall be delineated on the Final Subdivision Plat prior to the approval of said document by the Gladeville Utility District.
- C. Stakeout of all easements shall be performed by a Land Surveyor licensed in the State of Tennessee employed by the **Developer/Contractor** prior to the installation of water lines and meter vaults. Stakeout shall be undertaken utilizing available easement documents and shall include all sides of the easement(s). Licensed land surveyor shall provide a letter to **District** stating that easement(s) have been surveyed and flagged in accordance with the appropriate recorded easement documents. Construction of improvements shall not begin until the **District** has checked and observed the easement staking.
- D. Water lines crossing public rights-of-way do not require easements. Water lines crossing private roadway and driveways will require exclusive easements. Water lines crossing previously dedicated public utility easements do not require easement where the point of crossing occurs. Water lines crossing other exclusive public utility easements (electricity, gas, etc.) still require easements for the **District** from the **Owner/Applicant**.
- E. If circumstances arise during construction that changes the layout of the water line and subsequently places the water improvement outside of the easement, a new easement will be required. The **District Engineer** will prepare the revision and the Developer will be required to execute the new/revised easement document. The revised easement will then be re-recorded by the **District** in the Registrar's Office of Wilson County, Tennessee.
- F. Permanent easements that have been purchased or obtained through condemnation by the **DISTRICT** will be cleared of all trees that fall within the confines of the permanent easement. No consideration will be given for tree replacement in these circumstances after water line installation is complete.

END OF SECTION

SECTION 2.01

GENERAL PROJECT REQUIREMENTS

PART 1 - GENERAL

1.01 SECTION INCLUDES

- A. General Requirements

1.02 GENERAL REQUIREMENTS

- A. Any Contractor that is undertaking a project with public water improvements that are to become a part of the Gladeville Utility District water system shall possess and maintain an active contractor's license in the State of Tennessee. The contractor shall have an active BC, BC-B, MU-B, or MU-A.3 license. The contractor will be required to present evidence of licensure at the pre-construction meeting for each project they are to be engaged upon.
- B. Smoking and Fire Precautions: No smoking, fire, or use of any fire or explosion producing tools or equipment shall be permitted on the premises or at any locations where such may endanger said premises or the current operations thereon.
- C. Manufacturers Qualifications: The manufacturers of all materials and equipment used must be reputable and regularly engaged in the manufacture of the particular material or equipment for the use and service to which it will be subjected.
- D. Contractor Shall Pay for All Laboratory Inspection Service: All materials and equipment used in the construction of the project shall be subject to adequate inspection and testing in accordance with accepted standards. The laboratory or inspection agency shall be selected by the Contractor and approved by the District. Contractor to pay for all laboratory inspection services as a part of the Contract. Submit copies of all material test reports to the District.
- E. Compliance With State and Local Laws: Comply with all applicable requirements of state and local laws and ordinances to the extent that such requirements do not conflict with federal laws or regulations.
- F. Protection of Public and Private Property: Take special care in working areas to protect public and private property. The Contractor shall verify the presence of all underground utilities prior to beginning construction. The contractor shall replace or repair at his own expense any damaged water pipes, power and communication lines, or other public or private utilities, roads, curbs, gutters, sidewalks, drain pipes, ponds or pond structures, sewer drainage ditches, all

properties and fixtures (both permanent and temporary) fences, and all plantings, including grass or sod on the site of the work. Leave the site in original or better condition after all cleanup work has been done.

- G. Markers: Preserve all USGS, TVA, and State of Tennessee property markers and private markers. Do not remove or disturb any such markers without prior approval from the Owner. Any removal and replacement of such markers shall be at the expense of the Contractor.
- H. Non-discrimination: The Contractor agrees to hire qualified persons without regard to race, creed, color, sex, or national origin for the performance of the work specified in this contract, in accordance with state and federal laws.
- I. Pavement Repair and/or Replacement: Whenever pipe trenches are cut across or along existing pavement or shoulders, backfill same and restore traffic over the cuts as quickly as possible by constructing a temporary surface with eight (8) inches of compacted crusher run roadway base stone. Add material and otherwise maintain such surface until the permanent pavement is restored by the Contractor or until the entire project is accepted. Binder placement shall occur within seven calendar days after the completion of the road cut.
- J. Department of Transportation Permits: The District will secure any permits and provide bond as required by the Tennessee Department of Transportation. The Developer or his Site Engineer will secure any permits and provide bond as required to the Wilson County Road Commission for the installation of permanent facilities on county rights-of-way. All such work shall be coordinated with and be subject to the approval of the governing Road Commission or Department of Transportation.
- K. Approved Chemicals: All chemicals used during project construction or furnished for project operation, whether herbicide, pesticide, disinfectant, polymer, reactant, or of other classification, must show approval of either EPA or USDA. The use of all such chemicals and the disposal of residues shall be in strict conformance with instructions.
- L. Catalogue Data for Gladeville Utility District: Provide duplicate complete, bound sets of a compilation of catalog data of each manufactured item of mechanical and electrical equipment used in the work, and present this compilation to the **District** before final project close-out. Include descriptive data and printed installation, operating, and maintenance instruction (including a parts list for each item of equipment). Provide a complete double index as follows:
 - 1. Listing the products alphabetically by name.
 - 2. Listing alphabetically the names of manufacturers whose products have been incorporated in the work, together with their addresses and the names and addresses of the local sales representative.

- M. Operation and Maintenance Instruction to Gladeville Utility District: Where the specifications for specific equipment require that a factory service representative provide operation and maintenance instruction to the **District** for that equipment, this service is to be performed by prior arrangement with the District after and in addition to the manufacturer's instructions to the Contractor for installation and start-up. The individual performing the instruction to the **District** shall be trained and/or certified by the manufacturer as its authorized operation, maintenance, and service specialist. If the said specialist is not a regular full-time employee of the manufacturer, the specialist's qualifications shall be submitted to the **District** for review and approval prior to scheduling the site visit for instructions to the District.
- N. Operation of Water System: No Contractor shall operate valves, hydrants, pump stations or other appurtenances of the water system without the presence of a **DISTRICT** representative.
- O. Temporary Water for Contractors: Contractors shall obtain a temporary hydrant meter and accompanying backflow device from the **District** for use in obtaining temporary water for construction purposes. The Contractor shall complete a *GUD Fire Hydrant Meter Agreement for Off-site Use* to obtain the meter. A \$150.00 non-refundable service charge is required and contractor shall pay the water usage billed on a monthly basis. Charges will be based on the current schedule of rates which may be adjusted from time to time and for adhering to the **District** billing procedures. Contractor is responsible for the meter. Any damage to the meter will be assessed to the Contractor. No hydrant or water system connection is allowed without a **District** approved temporary meter and backflow device
- P. Utilities: The Contractor shall contact the owners of all underground utilities before beginning construction in the area. Carefully protect from damage all utilities in the vicinity of the work at all times. If it is necessary to repair, remove, and/or replace any such utility in order to complete the work properly, do so in compliance with the rules and regulations of the particular utility involved. Any such work shall be considered incidental to the construction or repairs of utility lines, and no additional payment will be allowed therefor. Existing water mains shall remain in service at all times during construction. Contractor shall provide any temporary piping necessary to maintain water service to existing customers.
- Q. Interruption of Water Service: Work that requires outage or interruption of existing water service shall be scheduled at least 7 days in advance of the proposed interruption of service. The **District** will provide notification to all affected customers.
- R. State Approved Plans: Construction shall not begin until State of Tennessee approved plans are in place. A copy of the approved plans shall be kept on-site during construction.

- S. Prior to start of construction, the Contractor shall schedule a pre-construction meeting with the **District** to review the project work requirements.

PART 2 - PRODUCTS

Not Used

PART 3 - EXECUTION

Not Used

END OF SECTION

SECTION 2.03

FIELD ENGINEERING

PART 1 - GENERAL

1.01

- A. The Contractor shall be responsible for providing and paying for any surveying or engineering services required during the construction. The Contractor must retain qualified personnel as work may require.
- B. Prior to the start of construction of the water system improvements, the approved Contractor or approved Utility Contractor shall submit a formal subgrade letter with certification and cut sheets showing that the ground elevations (profile) along the route of the water line is within ± 6 inches of final grade or subgrade, whichever is appropriate. A subgrade letter will also be required along the centerline of roads running parallel to proposed water lines where water services will be crossing the road(s). Each subgrade letter must be signed and sealed by either an engineer or surveyor licensed to practice in the State of Tennessee.
- C. The **District** shall be responsible only for inspections of all water lines and appurtenances.
- D. The **District** will not supply Contractor with any survey control points. The **District's** engineer of record can provide a CAD file of the water line design document upon request.

PART 2 - PRODUCTS

N/A

PART 3 - EXECUTION

N/A

END OF SECTION

SECTION 2.04

PROJECT COORDINATION AND ACCESS

PART 1 - GENERAL

- 1.01 The Contractor shall work in full cooperation with District personnel in order to provide safe access for purpose of inspection of all utility work.
- 1.02 The Contractor shall organize his work in such a manner that existing utility service is maintained to existing customers at all times.
- 1.03 The location of existing utilities is approximate only. It is the responsibility of the Contractor to contact the local utility companies for exact locations of all utilities prior to the beginning of construction.
- 1.04 Contractor shall operate no valves or utility appurtenances in the system. Only District representatives are authorized to operate valves and utility appurtenances.
- 1.05 No service relocations shall occur without a 7-day notice to the property owner.
- 1.06 No cut-ins shall occur without a 7-day notice and coordination with the **District**.
- 1.07 No more than two (2) cut-ins at a given time will be permitted by the **District**. Contractor shall ensure that all necessary materials and adequate equipment and personnel are on hand to achieve cut-ins in the **District** specified allowed outage period.
- 1.08 Hydrostatic testing shall not be started on a Friday through Sunday; or a day before a holiday; or later than 2 PM on a weekday to accommodate working schedules of **District** personnel.
- 1.09 Bacteriological testing will only be allowed on Monday through Thursday in order to allow for coordination of test samples with the laboratory. No tests will be allowed on a day before a **District** observed holiday.
- 1.10 **District** personnel are onsite to observe, facilitate and ensure that the conditions and requirements set forth in these Standard Specification are met. **District** personnel will not direct, coordinate or otherwise assist the Contractor's work forces or his subcontractors in their daily work activities.
- 1.11 The **District** is not responsible for the safety of the Contractor's work site, personnel or any other items related to safety. The responsibility of meeting all applicable safety requirements rests solely with the Contractor.

- 1.12 The Contractor shall provide a person on the job site authorized and capable of communicating intent and receiving instruction from **District** staff. The **District** has the right to shut down the job site if onsite Contractor personnel cannot communicate or fail to heed **District** instructions.

PART 2 - PRODUCTS

N/A

PART 3 - EXECUTION

N/A

END OF SECTION

SECTION 2.05

SHOP DRAWINGS & PRODUCT DATA

PART 1 - GENERAL

1.01 REQUIREMENTS INCLUDED

- A. Submit shop drawings and product data to the **District** for review and approval.

1.02 SHOP DRAWINGS

- A. Drawings shall be presented in a clear and thorough manner.
 - 1. Details shall be identified by reference to sheet and detail, schedule or room numbers shown on the Construction Drawings.
- B. Drawings shall be submitted at least three (3) weeks prior to the pre-construction meeting to allow the **District** adequate time for review and approval.

1.03 PRODUCT DATA

- A. Preparation
 - 1. Clearly mark each copy to identify pertinent products or models.
 - 2. Show performance characteristics and capacities.
 - 3. Show dimensions and clearances required.
 - 4. Show wiring or piping diagrams and controls.
- B. Manufacturer's standard schematic Drawings and Diagrams.
 - 1. Modify drawings and diagrams to delete information which is not applicable to the work.
 - 2. Supplement standard information to provide that specifically applicable to the work.

1.04 CONTRACTOR RESPONSIBILITIES

- A. Review Shop Drawings, Product Data and Samples prior to submission.
- B. Determine and verify:

1. Field measurements.
 2. Field construction criteria.
 3. Catalog numbers and similar data.
 4. Conformance with specifications.
- C. Coordinate each submittal with requirements of the work and of the Construction Plans.
- D. Notify the **District** in writing, at the time of submission, of any deviations in the submittals.
- E. Begin no fabrication or work which requires submittals until return of submittals with **District** stamp approval.

1.05 SUBMISSION

- A. Submit shop drawings/submittals to the **District** at least three (3) weeks prior to the pre-construction meeting.
- B. Number of submittals required:
1. Shop Drawings: Submit one (1) .pdf copy.
- C. Submittals shall contain:
1. Cover page.
 2. The date of submission and the dates of any previous submission.
 3. The project title.
 4. The names of the Contractor, supplier and manufacturer.
 4. Identification of the product.
 5. Field dimensions, clearly identified as such.
 6. Relation to adjacent or critical features of the work or materials.
 7. Applicable standards, such as ASTM or Federal Specification numbers.
 8. Identification of deviations from Contract Documents.

9. Identification of revisions on submittals.
10. A six (6) inch square blank space for **District** review stamps.
11. Contractor's stamp, initialed or signed, certifying to review of submittal, verification of products, field measurements and field construction criteria and coordination of the information within the submittal with requirements of the work and of Contract Documents.

1.06 RESUBMISSION REQUIREMENTS

- A. Make any corrections or changes in the submittals required by the **District** and resubmit until approved.
- B. Shop Drawing and Product Data:
 1. Revise initial drawings or data and resubmit as specified for the initial submittal.
 2. Indicate any changes which have been made other than those requested by the **District**.

1.07 DISTRIBUTION

- A. Shop Drawings and copies of Product Data which carry the **District's** letter of approval will be distributed as follows:
 1. **District** file copy. (.pdf)
 2. **District** inspector. (.pdf)
 3. Contractor. (.pdf)
- B. It is the responsibility of the Contractor to distribute his approved copies of Shop Drawings to suppliers.

PART 2 - PRODUCTS

N/A

PART 3 - EXECUTION

N/A

END OF SECTION

SECTION 2.06

TEMPORARY CONTROLS

PART 1 - GENERAL

1.01 REQUIREMENTS INCLUDED

- A. Provide and maintain methods, equipment and temporary construction, as necessary to provide controls over environmental conditions at the construction site and related areas under the Contractor's control; remove physical evidence of temporary facilities at completion of work.

1.02 DUST CONTROL

- A. Provide positive methods and apply dust control materials to minimize raising dust from construction operations and provide positive means to prevent air-borne dust from dispersing into the atmosphere.

1.03 WATER CONTROL

- A. Provide methods to control surface water to prevent damage to the Project, the site or adjoining properties.
 - 1. Control filling, grading and ditching to direct surface drainage away from excavations, pits, tunnels and other construction areas; and to direct drainage to proper runoff.
- B. Provide, operate and maintain hydraulic equipment of adequate capacity to control surface water.
- C. Dispose of drainage water in a manner to prevent flooding, erosion or other damage to any portion of the site or to adjoining areas, as required by local rules and regulations.

1.04 DEBRIS CONTROL

- A. Maintain all areas under Contractor's control free of extraneous debris.
- B. Initiate and maintain a specific program to prevent accumulation of debris at the construction site, storage and parking areas, or along access roads and haul routes.

1. Provide containers for deposit of debris.
 2. Prohibit overloading of trucks to prevent spillage on access roads or haul routes.
 3. Provide periodic inspection of traffic areas to enforce requirements.
- C. Schedule periodic collection and disposal of debris. Provide additional collections and disposals of debris whenever the periodic schedule is inadequate to prevent accumulation.

1.05 POLLUTION CONTROL

- A. Provide methods, means and facilities required to prevent contamination of soil, water or atmosphere by the discharging of noxious substances from construction operations.
- B. Provide equipment and personnel, perform emergency measures required to contain any spillage, and to remove contaminated soils or liquids.
1. Excavate and dispose of any contaminated earth off-site and replace with suitable compacted fill and topsoil.
- C. Take special measures to prevent harmful substances from entering public waters.
1. Prevent disposal of waste, effluents, chemicals or other such substances adjacent to streams or in sanitary sewers.
- D. Provide system for control of atmospheric pollutants.
1. Prevent toxic concentrations of chemicals.
 2. Prevent harmful disposal of pollutants into the atmosphere.

1.06 TRAFFIC CONTROL

- A. Contractor shall provide traffic control devices and signage as set forth by the latest edition of the Manual of Uniform Traffic Control Devices to protect the public where utility work is undertaken inside roadway areas.

PART 2 - PRODUCTS

N/A

PART 3 - EXECUTION

N/A

END OF SECTION

SECTION 2.07

TRANSPORTATION AND HANDLING

PART 1 – GENERAL

1.01 PACKING AND TRANSPORTATION

- A. Require supplier to package products in boxes or crates for protection during shipment, handling, and storage. Protect sensitive products against exposure to elements and moisture. All piping valves, fittings, etc. shall be stored (or bagged) in such a manner so as to prevent dirt, silt, or debris from entering the product.
- B. Protect sensitive equipment and finishes against impact, abrasion, and other damage.

1.02 DELIVERY

- A. Arrange deliveries of products in accordance with construction schedules and in ample time to facilitate inspection prior to installation.
- B. Coordinate to avoid conflict with work and conditions at the site. Specifically coordinate to determine:
 - 1. Work of the **District**.
 - 2. Work of other contractors.
 - 3. Availability of equipment and personnel for handling products.
 - 4. **District's** use of premises.
- C. Deliver products in undamaged condition, in manufacturer's original containers or packaging, with identifying labels intact and legible.
- D. Clearly mark partial deliveries of component parts of equipment to permit easy accumulation of parts and to facilitate inspection prior to installation.
- E. Immediately on delivery, inspect shipments to assure:
 - 1. Compliance with Construction Plans and approved submittals.
 - 2. Quantities are correct.
 - 3. Containers and packages are intact and that labels are legible.
 - 4. Products are properly protected and undamaged.

1.03 PRODUCT HANDLING

- A. Provide equipment and personnel to handle products by methods to prevent soiling or damage to products or packaging.
- B. Provide additional protection during handling as necessary to prevent scraping, marring, or otherwise damaging products or surrounding spaces.
- C. Handle products by using methods that will prevent bending or over stressing.
- D. Lift heavy components only at designated lifting points.

1.04 UNUSED MATERIALS AND SITE CLEANUP

- A. Contractor shall remove any and all unused, damaged or salvaged materials at the completion and acceptance of the work.
- B. Storage areas shall be left clean, neat, re-landscaped at the end of the construction work and any trash and dumpsters removed from the site.

PART 2 – PRODUCTS

Not Used

PART 3 – EXECUTION

Not Used

END OF SECTION

SECTION 2.08

STORAGE AND PROTECTION

PART 1 – GENERAL

1.01 STORAGE, GENERAL

- A. Store products immediately on delivery in accordance with manufacturer's instructions with seals and labels intact. Protect until installed.
- B. Arrange storage in a manner to provide access for maintenance of stored items and for inspection.

1.02 EXTERIOR STORAGE

- A. Provide substantial platforms, blocking, or skids to support fabricated products above ground; slope to provide drainage. Protect products from soiling and staining.
- B. Store loose granular materials on clean, solid surfaces such as pavement, or on rigid sheet materials to prevent mixing with foreign matter.
- C. Provide surface drainage to prevent erosion and ponding of water.
- D. All pipe, valves, and fittings shall be stored with the ends capped to prevent debris from entering the materials.
- E. All pipe, valves, and fittings shall have the ends sealed while stored to prevent debris or foreign objects from entering the pipe.

1.03 MAINTENANCE OF STORAGE

- A. Verify that surfaces of products exposed to the elements are not adversely affected; that any weathering of finishes is acceptable under requirements of Contract Documents.

PART 2 - PRODUCTS

Not Used

PART 3 – EXECUTION

Not Used

END OF SECTION

SECTION 2.09

PROJECT CLOSEOUT

PART 1 – GENERAL

1.01 FINAL COMPLETION

- A. When the project is considered to be complete, the Contractor shall coordinate a final inspection with the **District's** jobsite inspector.
- B. **District's** Action During Final Inspection:
 - 1. Inspect to verify the status of completion within seven (7) working days.
 - 2. If **District** considers work incomplete or defective, they will promptly notify Contractor in writing, listing deficiencies.
- C. Contractor's Duties: Take immediate action to correct deficiencies, and send certification to **District** that any deficiencies have been corrected.
- D. When **District** determines that work is acceptable, they will request Contractor to make closeout submittals including Maintenance Bond, dedication of improvements.

1.02 DISTRICT OCCUPANCY

- A. **District** will occupy the Project, or designated portion of the Project once all deficiencies have been corrected and final acceptance has granted.
- B. Contractor's Duties:
 - 1. Make corrections listed on punch list.
 - 2. Perform final clean-up.

1.03 CONTRACTOR'S CLOSEOUT SUBMITTALS REQUIRED

- A. Project Record Documents: Comply with Section 2.10.
- B. Evidence of Payment and Release of Liens: Contractor should advertise in local paper for two (2) consecutive weeks of project closure and provide **District** with evidence of same.
- C. Copies of all test results.

PART 2- PRODUCTS

Not Used

PART 3- EXECUTION

Not Used

END OF SECTION

SECTION 2.10

PROJECT RECORD DOCUMENTS

PART 1 – GENERAL

1.01 SECTION INCLUDES

A. The Policy Manual requires the Contractor to maintain a record copy of the following for **District's** review:

1. TDEC Approved construction plans.
2. Approved shop drawings, product data, and samples.
3. Records of all changes made during construction.

B. In addition to the above, the Contractor shall maintain a record copy of the following where applicable:

1. Field test results.
2. Operation and maintenance manuals.

1.02 RECORDING

A. Record information concurrently with construction progress.

1. Do not conceal work until required information has been recorded by the **District**.
2. Coordinate with District personnel on obtaining GPS shots of all installed water materials.

PART 2 – PRODUCTS

Not Used

PART 3 – EXECUTION

Not Used

END OF SECTION

SECTION 2.11

CLEANING

PART 1 - GENERAL

1.01 CLEANING

- A. The Contractor is responsible for cleanup.
- B. Maintain premises and public properties free from accumulations of waste, debris, and rubbish caused by operations.
- C. Keep streets clean from mud, dirt, debris, and other materials removed from the job site. Promptly remove mud and dirt tracked by vehicles from street surfaces.
- D. At completion of work, remove waste materials, rubbish, tools, equipment, machinery, and surplus materials. Clean all sight-exposed surfaces. Leave project clean and ready for occupancy.
- E. Conduct cleaning and disposal operations to comply with local ordinances and anti-pollution laws.
 - 1. Do not burn or bury rubbish and waste materials on project site or in trench.
 - 2. Do not dispose of volatile waste such as mineral spirits, oil and paint thinner in storm drains or sanitary sewers.
- F. Hazard Control:
 - 1. Store volatile wastes in covered metal containers, and remove from premises daily.
 - 2. Prevent accumulation of waste which might cause hazardous conditions.
 - 3. Provide adequate ventilation during use of volatile and noxious substances.

1.02 DURING CONSTRUCTION

- A. Clean building, grounds and public properties and keep free from accumulations of waste materials and rubbish.
- B. Wet down dry materials and rubbish to prevent dust.

- C. At reasonable intervals during progress of work, but in no case less than once a week, clean site and public properties and dispose of waste materials, debris and rubbish.
- D. Provide on-site containers for collection of waste materials, debris, and rubbish.
- F. No debris shall be permitted to accumulate on site except in a container designed for debris removal.

1.03 FINAL CLEANING

- A. Remove waste, debris, and surplus materials from site. Clean grounds; remove stains, spills, and foreign substances from paved areas and sweep clean. Rake clean other exterior surfaces.
- B. Maintain cleaning until Final Completion.
- C. Prior to Final Completion, or **District** occupancy, Contractor shall conduct an inspection of sight exposed interior and exterior surfaces, and all work areas, to verify that the entire work is clean.
- D. Paint bonnets of all newly installed fire hydrants with the appropriate flow status color based on the **District** instructions. Hydrants are to have the bonnets color coded in accordance with NFPA 291. Paint shall be factory applied and shall be Tnemec Series 2H Hi-Build Tnene-Gloss or Sherwin-Williams Series B54-Z Pro Industrial Enamel HS Enamel Alkyd Gloss.

PART 2 - PRODUCTS

Not Used

PART 3 - EXECUTION

Not Used

END OF SECTION

SECTION 2.12

TRENCHING, BACKFILLING AND COMPACTION FOR UTILITIES

PART 1 - GENERAL

1.01 REQUIREMENTS INCLUDED

- A. Excavation for buried utility material.
- B. Provide necessary sheeting, shoring and bracing.
- C. Prepare trench bottom with appropriate materials.
- D. De-water excavations as required.
- E. Place and compact granular beds, as required, and backfill.

1.02 RELATED WORK

- A. Section 2.13: Unclassified Excavation for Utilities
- B. Section 3.01: Water Lines

1.03 PRECAUTIONS

- A. Contractor shall shore and brace all open cut trenches as required by State and Federal Laws and Local Ordinances; conform with recommendations set forth in AGC Manual of Accident Prevention in Construction; protect life, property, or work; and avoid excessively wide or deep cuts in unstable material.
- B. Notify utility companies when necessary to disturb existing facilities and abide by their requirements for repairing and replacing.
- C. Protect all vegetation and other features to remain.
- D. Protect all benchmarks, property pins and survey points. Any damaged or destroyed property pins shall be replaced at the contractor's expense.

PART 2 - PRODUCTS

N/A

PART 3 - EXECUTION

3.01 PREPARATION

- A. Install barriers and other devices to protect areas adjacent to construction.
- B. Protect and maintain all benchmarks and other survey points.

3.02 EXCAVATION TRENCHES

- A. Perform in such a manner as to form a suitable trench in which to place the pipe and so as to cause the least inconvenience to the public. Contractor shall barricade all open excavations to prevent access by the public.
- B. Trench width shall be the width of the pipe O.D. plus 36 inches minimum.
- C. Cut pavement along neat, straight lines with either a pavement breaker or pavement saw.
- D. Trench depth and pipe cover: To provide minimum cover as specified in Section 3.10, over the top of the pipe. Water lines crossing roadways in industrial/commercial developments shall have a minimum of 42-inches of cover. Water lines outside of roadway areas shall have a minimum of 36-inches of cover. In residential developments, roadway crossings shall have a minimum of 36-inches of cover unless otherwise noted on drawings.
- E. Align trench as shown on the drawings unless a change is necessary to miss an unforeseen obstruction.
- F. When unstable soil is encountered at the trench bottom, remove it to a depth required to assure support of the pipeline and backfill to the proper grade with coarse aggregate AASHTO M-43, Size No. 2 or 3.
- G. Remove rock encountered in trench excavation to a depth of twelve (12) inches below the bottom of the pipe barrel, backfill with an approved material, and compact to uniformly support the pipe. In no case shall solid rock exist within twelve (12) inches of the finished pipeline.
- H. Do not excavate more than 200 feet ahead of pipe laying activities.

3.03 SHEETING, SHORING AND BRACING

- A. Contractor is solely responsible for job site safety. Contractor shall determine when necessary, to furnish, put in place, and maintain such sheeting, bracing, etc., as may be required to support the sides of the excavation and to prevent movement.
- B. Take care to prevent voids outside the sheeting.

- C. If voids are formed, immediately fill and compact to the satisfaction of the Engineer.
- D. Unless adjacent facilities will be damaged, remove all sheeting, shoring, and bracing after backfill has been placed to a depth of 18 inches over the pipeline.
- E. Cut shoring off at the top of the pipe and leave the lower section in the trench.
- F. The District nor the Engineer is responsible for job site safety.

3.04 USE OF EXPLOSIVES

- A. If required, blasting will be permitted on this project. The Contractor is responsible and shall obtain all necessary permits from the State Fire Marshal for all blasting activities.

3.05 DISPOSAL OF EXCAVATED MATERIAL

- A. Satisfactorily dispose of all excess excavated material that cannot be used for or is not suitable for embankments.

3.06 UNAUTHORIZED EXCAVATION

- A. Unauthorized excavation is defined as all excavation outside or below the proposed lines and grades shown on the drawings.
- B. Backfill areas of unauthorized excavation with the type material necessary (earth, rock or concrete) to ensure the stability of the structure or construction involved.
- C. Unauthorized excavation or backfill to replace same shall not be a pay item.

3.07 REMOVAL OF WATER

- A. Keep excavated areas free of water while work is in progress.
- B. Well-pointing shall be performed if required.
- C. Take particular precautions to prevent the displacement of structures or pipelines as a result of accumulated water.
- D. Dewatering shall be discharged through filter bags, straw bales or other approved devices to prevent muddy water from entering streams and ponds.

3.08 OBSTRUCTIONS

- A. Obstructions shown on the drawings are for information only and do not guarantee their exact locations nor that other obstructions are not present.

- B. When utilities or obstructions are not shown on the drawings but are present off the roadway at the location of the proposed pipeline route, the Contractor should notify the appropriate utility owner prior to continuing with any installation.
- C. Exercise due care in excavating adjacent to existing obstructions and do not disturb same unless absolutely necessary.
- D. In the event obstructions are disturbed, repair or replace as quickly as possible to the condition existing prior to their disturbance.
- E. Coordinate all obstruction relocation with the appropriate utility owner.

3.09 INITIAL BEDDING

- A. Do not begin backfilling before the Engineer has inspected the grade and alignment of the pipe, the bedding of the pipe, and the joints between the pipe. If backfill material is placed over the pipe before an inspection is made, reopen the trench in order for an inspection to be made.
- B. Initial bedding from a point 12 inches below the pipe to a point 12 inches over the top of the pipe shall be No. 67 stone. Placement of this stone backfill around the pipe shall be carefully placed with special attention to insuring adequate placement of stone around the lower haunches of the pipe.
- C. In roadway or paved areas, initial bedding from a point 12 inches below the pipe to the top of the ditch shall be No. 67 stone.

3.10 FINAL BACKFILLING

- A. From 12 inches above the top of the pipe, perform final backfilling depending upon the location of the work and danger from subsequent settlement. Where pipe is located inside paved roadway or paved areas, final backfilling shall be with No. 67 stone. In roadway areas, cap the top 8 inches of the trench with compacted crusher run roadway base stone.
- B. Backfilling in Unimproved or Easement Areas:
 - 1. Dispose of and replace all soft or yielding material which is unsuitable for trench backfill with suitable material.
 - 2. Deposit backfill to the surface of the ground by dragline, bulldozer, or other suitable equipment in such a manner so as not to disturb the pipe. Backfill material may contain broken stones that make up approximately 1/2 of the backfill's total volume. However, if this type of backfill is used, there must be enough spalls and earth materials to fill all voids completely. The maximum dimension of individual stones or rock in such backfill shall not exceed 6 inches. The backfill material shall be tamped and thoroughly compacted in layers equal to compacted density equivalent

to that of adjacent earth material. Use special care to prevent the operation of backfilling equipment from causing any damage to the pipe.

3. Wherever excavation has been made and/or areas disturbed within easements across private property, the top 6 inches of backfill material shall consist of topsoil free from large clods, vegetable matter, debris, roots, stone, and/or other objectionable materials. Clay, red dirt, etc. will not be allowed as top coat material.
4. Dispose of all surplus excavated material and remove from the site.
5. Prior to final acceptance, remove all mounds or restore any settled areas to the elevation of the surrounding terrain.

3.11 USE OF ROAD PLATES

- A. Steel roadway plates are permitted for use in applications where pipeline installation activity will continue on the following work day or over a weekend. Steel plates shall be secured in a manner to prevent movement and vibration. Steel plates placement will not be allowed for long term periods without the previous approval by the **District**.

END OF SECTION

SECTION 2.13

UNCLASSIFIED EXCAVATION FOR UTILITIES

PART 1 – GENERAL

1.01 SECTION INCLUDES

- A. The work called for by this section shall consist of clearing and grubbing, loosening, loading, removing, and disposing of, in the specified manner, all wet and dry materials encountered that must be removed for construction purposes; furnishing, placing, and maintaining all sheeting, shoring, bracing, and timbering necessary for the proper protection and safety of the work, the workmen, the public, and adjacent property and improvements; the dewatering of trenches and other excavations; the preparation of fills and embankments; the removal of unsuitable material from outside the normal limits of excavation and, where ordered by the Engineer, their replacement with suitable materials; and all other grading or excavation work incidental to or necessary for the work. This work shall be performed as specified below.

1.02 QUALITY ASSURANCE

- A. Codes and Standards: Perform excavation work in compliance with applicable requirements of governing authorities having jurisdiction.

1.03 JOB CONDITIONS

- A. Existing Utilities: Locate existing underground utilities in areas of work. If utilities are to remain in place, provide adequate means of support and protection during earthwork operations.
- B. Should uncharted, or incorrectly charted, piping or other utilities be encountered during excavation, consult Utility Owner immediately for directions. Cooperate with Utility Companies in keeping respective services and facilities in operation. Repair damaged utilities to satisfaction of Utility Owner.
- C. Do not interrupt existing utilities serving facilities occupied and used by District or others, during occupied hours, except when permitted in writing by District and then only after acceptable temporary utility services have been provided.
 - 1. Provide minimum of 7 day notice to District before interrupting any water line.

- D. Demolish and completely remove from site existing underground utilities indicated to be removed. Coordinate with utility companies for shut-off of services if lines are active.
- E. Preserve from damage surveying monuments, property pins, and similar items. If disturbed or damaged by construction operations, pay the cost of restoration by a registered surveyor.
- F. Protect structures, utilities, sidewalks, pavements, and other facilities from damage caused by settlement, lateral movement, undermining, washout and other hazards created by earthwork operations.

1.04 PROTECTION

- A. Protect excavations by shoring, bracing, sheet piling, underpinning, or other methods required to prevent cave-in or loose soil from falling into excavation work.
- B. Underpin adjacent structures which may be damaged by excavation work, including service utilities and pipe chases.
- C. Notify System and Engineer of Record of unexpected subsurface conditions and discontinue work in affected area until notification to resume work.
- D. Protect bottom of excavations and soil adjacent to and beneath foundations from frost.
- E. Guard excavation bottoms against freezing when atmospheric temperature is less than 35°F.
- F. Protect trees, shrubbery, fences, poles, and all other property and surface structures during construction operations. Fences, poles, or other man made surface improvements which are moved or disturbed shall be restored to the original conditions after construction is completed. Trees, shrubbery, or other vegetation which are approved for removal in order to facilitate construction operations shall be removed completely, including stumps and main roots. Responsibility for damage or claims for damage caused by construction operations to shrubbery or other landscape improvements shall be assumed by Contractor.

1.05 SAFETY

- A. Contractor is solely responsible for job site safety. The District nor the Engineer are responsible for job site safety.

- B. Barricades, Guards, and Safety Provisions: Contractor shall provide all barricades, fences, construction signs, torches, flashing lights, lanterns, guards, and flagmen as required during the progress of the construction work and until it is safe for traffic to use the roads and streets. Material piles, equipment, and pipe which may serve as obstructions to traffic shall be enclosed by fences or barricades and shall be protected by proper lights when the visibility is poor. The rules and regulations of OSHA and appropriate authorities respecting safety provisions shall be observed.
- C. Structure Protection: Provide temporary support, protection, and maintenance of underground and surface drains, sewers, and other obstructions encountered during the progress of the work. Structures which may have been disturbed shall be restored upon completion of the work.

1.06 DEVIATIONS OCCASIONED BY STRUCTURES OR UTILITIES

- A. Wherever obstructions are encountered during the progress of the work which occupy the space required for the pipeline, District or Engineer shall have the authority to order a deviation from the line and grade or arrange with the Owners of the structures for the removal, relocation, or reconstruction of the obstructions.
- B. Where gas, water, telephone, electrical, or other existing utilities directly interfere with the vertical or horizontal alignment of the pipeline, District or Engineer will order a change in grade or alignment or will arrange with the Owners of the utilities for their removal.

1.07 DUST CONTROL

- A. When ordered by District or Engineer, furnish and distribute over traveled road surfaces which have not been fully restored an application of regular flake calcium chloride having a minimum calcium chloride content of 77 percent. Rate of application shall be 3 pounds/square yard for the flake calcium chloride. Water may also be used for dust control

1.08 MAINTENANCE OF THE TRAFFIC AND CLOSING OF STREETS

- A. Carry on the work in a manner which will cause a minimum of interruption to traffic, and do not close to through travel more than two consecutive blocks, including the cross street intersected. Where traffic must cross open trenches, provide bridges at street intersections and driveways. Post signs indicating that a street is closed and necessary detour signs for the proper maintenance of traffic. Before closing any streets notify responsible municipal authorities.

PART 2 – PRODUCTS

2.01 SOIL MATERIALS

- A. Satisfactory soil materials are defined as those complying with ASTM D2487 unified soil classification system groups GW, GP, GM, SM, SW and SP.
- B. Unsatisfactory soil materials are defined as those complying with ASTM D2487 unified soil classification system GC, SC, ML,MH, CL, CH, OL, OH and PT.
- C. Drainage Fill: Washed, evenly graded mixture of crushed stone, or crushed or uncrushed gravel, with 100% passing a 1-1/2" sieve and not more than 5% passing a No. 4 sieve.
- D. Coarse Aggregate Refill for Unsuitable Soil: AASHTO M43, Size No. 2 or 3.
- E. Backfill and Fill Materials: Satisfactory soil material of clay, rock, or gravel not larger than 2" in any dimension, free of debris, waste, frozen materials, vegetable and other harmful matter.

2.02 FILTER FABRIC IN UNSUITABLE SOIL AREAS

- A. In areas where unsuitable soil is encountered, and prior to placement of any refill material, the trench area where refill is to be placed shall be lined on the bottom and sides with a geotextile fabric such as Mirafi-S800 or approved equal.

PART 3 – EXECUTION

3.01 PREPARATION OF THE SITE

- A. Before starting construction, remove from the work site all vegetable growth (except as hereinafter excluded), debris, and/or other objectionable matter as well as any buildings and/or other structures that the Construction Documents specifically indicate are to be removed. Dispose of these refuse materials in a manner acceptable to the Engineer.
- B. In certain areas it may be desirable for existing trees, shrubs, or other vegetation on the site to be preserved for the permanent landscape. Such vegetation may be specifically listed in the specifications, marked on the site, or identified by the Engineer. In no case damage or remove such growth without written permission from the Engineer.
- C. If the area to be excavated is occupied by trees, brush, or other vegetable growth, clear such growth and grub the excavated area and remove all large roots to a depth of not less than 2' below the bottom of the proposed construction. Dispose of the growth removed. Fill all holes or cavities created during this work that extend below the subgrade elevation with suitable material, and compact to the same density as the surrounding material.

- D. Trees, cultivated shrubs, etc., that are situated within public rights-of way and/or construction easements through private property but not directly within the excavation area shall remain undisturbed unless it is necessary to remove them so that the work can be performed safely. Take special precautions to protect and preserve such growth throughout all stages of the construction.

3.02 EXCAVATION

- A. Excavation is unclassified, and includes excavation to subgrade elevations.
- B. Trenches shall be neatly excavated to the alignment and depth required for the proper installation of pipe, bedding material and appurtenances. Trenches shall be opened up far enough ahead of pipe laying to reveal obstructions, but in general shall not include more than 200 feet of continuous open trench at any time. Contractor shall schedule operations so that no more than 20 feet of open trench is left overnight and if occurring, appropriate warning, flagging and barriers shall be in place to protect the public.

3.03 UNSUITABLE MATERIALS

- A. Whenever muck, quicksand, soft clay, swampy ground, or other material unsuitable for foundations, subgrade, or backfilling is encountered, remove it and continue excavation until suitable material is encountered. The material removed shall be disposed of in the manner described below. Then refill the areas excavated for this reason with stone as specified in 2.01.D above and up to the level of the crushed stone pipe bedding. Prior to placement of the refill stone, wrap the sides and bottom of the pipe trench with soil stabilization fabric up to the top of the water pipe and fold over the pipe prior to placing final bedding and backfill.

3.04 ROCKS AND BOULDERS

- A. Any material that is encountered within the limits of the required excavation that cannot be removed except by drilling and /or blasting, including rock, boulders, masonry, hard pan, chert, shale, street and sidewalk pavements, and/or similar materials, shall be considered as rock excavation. Rock material shall be considered where it cannot be removed by a trackhoe by ripping the material.
- B. Should rock be encountered in the excavation, remove it by blasting, rock saws, rock trencher, hoe ram or otherwise. Where blasts are made, cover the excavation with enough excavation material and/or timber or steel matting to prevent danger to life and property. The Contractor shall secure, at his own expense, all permits required by law for blasting operations and the additional hazard insurance required. Observe all applicable laws and ordinances pertaining to blasting operations.

- C. Excavate rock over the horizontal limits of excavation and to a depth of not less than 12 inches below the bottom of pipe, then backfill the space below grade with No. 67 crushed stone, tamp to the proper grade, and make ready for construction.

3.05 DISPOSAL OF MATERIALS

- A. Whenever practicable, all materials removed by excavation that are suitable for backfilling pipe trenches or for other purposes shown on the drawings or directed by the District shall be used for these purposes. Any materials not so used shall be considered waste materials and disposed of by the Contractor as specified below.
- B. Once any part of the work is completed, properly dispose of all surplus or unused materials (including waste materials) left within the construction limits of that work. Leave the surface of the work in a neat and workmanlike condition, as described below.

3.06 SHEETING, SHORING AND BRACING

- A. Take special care to avoid damage wherever excavation is being done. Sufficiently sheet, shore, and brace the sides of all excavations to prevent slides, cave-ins, settlement, or movement of the banks and to maintain the specified trench widths. Use solid sheets in wet, saturated, or flowing ground. All sheeting, shoring, and bracing shall have enough strength and rigidity to withstand the pressures exerted, to keep the walls of the excavation properly in place, and to protect all persons and property from injury or damage. Separate payment will not be made for sheeting, shoring, and bracing, which are considered an incidental part of the excavation work.
- B. Wherever employees may be exposed to moving ground or cave-ins, shore and lay back exposed earth excavation surfaces more than 5' high to a stable slope, or else provide some equivalent means of protection. Effectively protect trenches less than 5' deep when examination of the ground indicates hazardous ground movement may be expected. Guard the wall and faces of all excavations in which employees are exposed to danger from moving ground by a shoring system, sloping of the ground, or some equivalent protection.
- C. Comply with all OSHA standards in determining where and in what manner sheeting, shoring, and bracing are to be done. The sheeting, shoring, and bracing system shall be designed by a professional engineer licensed in the State of Tennessee. The Contractor is solely responsible for the safety of the site and all employees, the effectiveness of the system, and any damages or injuries resulting from the lack or inadequacy of sheeting, shoring, and bracing. The District nor the Engineer are responsible for job site safety.

- D. Where excavations are made adjacent to existing buildings or structures or in paved streets or alleys, take particular care to sheet, shore, and brace the sides of the excavation so as to prevent any undermining of or settlement beneath such structures or pavement. Underpin adjacent structures wherever necessary, with approval of the Engineer.
- E. Do not leave sheeting, shoring, or bracing materials in place unless this is called for by the drawings, ordered by the District, or deemed necessary or advisable for the safety or protection of the new or existing work or features. Remove these materials in such a manner that the new structure or any existing structures or property, whether public or private, will not be endangered or damaged and the cave-ins and slides are avoided.
- F. Fill and compact all holes and voids left in the work by the removal of sheeting, shoring, or bracing as specified herein.
- G. The Contractor may use a trench box, which is a prefabricated movable trench shield composed of steel plates welded to a heavy steel frame. The trench box shall be designed to provide protection equal to or greater than that of an appropriate shoring system.
- H. Dewatering: Prevent surface water and subsurface or ground water from flowing into excavations and from flooding project site and surrounding area.
- I. Do not allow water to accumulate in excavations. Remove water to prevent softening of subgrade foundation bottoms, undercutting footings, and soil changes detrimental to stability of subgrades and foundation. Provide and maintain pumps, well points sumps, suction and discharge lines, and other dewatering system components to convey water away from excavations.
- J. Establish and maintain temporary drainage ditches and other diversions outside excavation limits to convey rain water removed from excavations to collecting or run-off areas. Do not use trench excavations as temporary drainage ditches.

3.07 BORROW EXCAVATION

- A. Whenever the backfill of excavated areas or the placement of embankments requires more material than is available from authorized excavations, or whenever the backfill material from such excavations is unsuitable, then obtain additional material from other sources. This may require the opening of borrow pits at points accessible to the work. Before a borrow pit is opened, the quality and suitability of its material shall be approved by the District.
- B. Excavate borrow in such a way that the remaining surfaces and slopes are reasonably smooth and that adequate drainage is provided over the entire area. Construct drainage ditches wherever necessary to provide outlets for water to the

nearest natural channel, thus preventing the formation of pools in the pit area. Leave the sides of borrow pit cuts at a maximum slope of 2:1 unless otherwise directed by the Engineer.

- C. Properly clear and grub borrow pits, and remove all objectionable matter from the borrow pit materials before placing it in the backfill.
- D. The taking of materials from borrow pits for use in the construction of backfill, fills, or embankment shall be considered an incidental part of the work.

3.08 BACKFILLING

- A. Conduct backfilling around manholes, inlet, outfalls, and/or structures in the same manner as specified for water lines, gravity sewers and/or force mains except that even greater care is necessary to prevent damage to the utility structure.
- B. Perform backfilling so as not to disturb or damage any pipe and/or structure against which the backfilling is being placed. If any pipe or structure is damaged and/or displaced during backfilling, open up the backfill and make whatever repairs are necessary.
- C. Backfilling shall take place immediately after pipe installation in trench, except that all required GPS information shall be collected prior to beginning backfilling.
- D. Backfilling of pipe inside paved areas or roadway shall be stone backfill, No. 67 stone.

3.09 MAINTENANCE

- A. Seed and maintain in good condition all excavated areas, trenches, fills, embankments, and channels until final acceptance by the District.
- B. Final restoration shall occur within 30 days of pipe installation.
- C. Maintain trench backfill at the approximate level of the original ground surface by periodically adding backfill material wherever necessary and whenever directed to do so by the District. Continue such maintenance until final acceptance of the project, or until District issues a written release.

3.10 SLOPES

- A. Neatly trim all open cut slopes, and finish to conform either with the slope lines shown on the drawings or the directions of the District. Leave the finished surfaces of bottom and sides in reasonably smooth and uniform planes like those normally obtainable with hand tools, though the Contractor will not be required to use hand methods if he is able to obtain the required degree of evenness with

mechanical equipment. Conduct grading operations so that material is not removed or loosened beyond the required slope.

END OF SECTION

SECTION 2.14

EROSION CONTROL

PART 1 - GENERAL

1.01 DESCRIPTION

- A. This work shall consist of erosion control on all cut and fill operations, excavation, backfill, or other construction activities within the limits of the construction site, within any temporary or permanent easements, and within any borrow site used during the period of construction. The protection of these sites shall continue throughout the construction period. During flood seasons, protect the sites by sandbagging, the pumping of water, and any other means appropriate to restrain flooding of plant and equipment. During dry weather, sprinkle the sites with water or use other means as necessary to provide dust control. In case of abnormally cold weather, any construction such as excavation work may be delayed until warmer weather or covered to prevent freezing.
- B. The temporary pollution control provisions contained herein shall be coordinated with the permanent erosion control features, to ensure economical, effective, and continuous erosion control throughout the construction and post-construction period.
- C. GUD does not obtain or provide erosion control plans for water line designs related to new development. The site engineer is responsible for all erosion control permitting as part of the overall site development.

PART 2 - PRODUCTS

2.01 TEMPORARY BERMS

- A. A temporary berm is constructed of compacted soil, with or without a shallow ditch, at the top of fill slopes or transverse to centerline on fills.
- B. These berms are used temporarily at the top of newly constructed slopes to prevent excessive erosion until permanent controls are installed or slopes stabilized.

2.02 TEMPORARY SLOPE DRAINS: A temporary slope drain is a facility consisting of stone gutters, fiber mats, plastic sheets, concrete or asphalt gutters, half round pipe, metal pipe, plastic pipe, sod, or other material that may be used to carry water down slopes to reduce erosion.

- 2.03 SEDIMENT STRUCTURES: Sediment basins, ponds, and traps, are prepared storage areas constructed to trap and store sediment from erodible areas in order to protect properties and stream channels below the construction areas from excessive siltation.
- 2.04 FILTER BAGS: Filter bags shall be employed in any locations where dewatering of the pipe trench is occurring to prevent mud, silt and debris from entering waterways.
- 2.05 CHECK DAMS: Check dams are barriers composed of large stones, sand bags, or other proprietary products placed across or partially crossing a natural or constructed drain way.
- 2.06 TEMPORARY SEEDING AND MULCHING: Temporary seeding and mulching are measures consisting of seeding, mulching, fertilizing, and matting utilized to reduce erosion. All cut and fill slopes including waste sites and borrow pits shall be seeded when and where necessary to eliminate erosion.
- 2.07 BALED HAY OR STRAW CHECKS
- A. Baled hay or straw erosion checks are temporary measures to control erosion and prevent siltation. Bales shall be either hay or straw containing five (5) cubic feet or more of material.
 - B. Baled hay or straw checks shall be used where the existing ground slopes toward or away from the embankment along the toe of slopes, in ditches, or other areas where siltation erosion or water runoff is a problem.
- 2.08 EROSION WATTLES
- A. Erosion wattles containing agricultural wheat straw, rice straw or coconut husks may be used for existing ground slopes to control erosion and prevent filtration.
- 2.09 TEMPORARY SILT FENCES: Silt fences are temporary measures utilizing woven wire or other approved material attached to posts with filter cloth imposed or burlap, plastic filter fabric, etc., attached to the upstream side of the fence to retain the suspended silt particles in the runoff water.
- 2.10 EROSION CONTROL BLANKETS
- A. Where needed or as directed by the **DISTRICT**, provide erosion control matting to slow down water flow, prevent silt and erosion and promote re-vegetation.
 - B. Blanket shall be rolled erosion control product composed of 70% agricultural wheat straw and 30% organic coconut fiber evenly distributed and mechanically stitch-bonded on maximum two-inch centers to a top and bottom netting. The netting shall be 100% biodegradable.

PART 3 - EXECUTION

- 3.01 **PROJECT REVIEW:** At the Preconstruction Conference the Contractor shall meet with the Site Engineer and go over in detail the expected problem areas in regard to the erosion control work. Different solutions should be discussed so that the best method might be determined. It is the basic responsibility of the Contractor to develop an erosion control plan acceptable to the Engineer of Record and the State of Tennessee. This plan shall comply with P.6. 100-4, Section 319, TCA 69-3-101, et.seq., Subsection 69-3-108 and Subsection 69-3-114 and the Division of Construction Grants and Loans General Permit for Utility Line Crossings, Chapter 1200-4-7.09.
- 3.02 The project drawings show the minimum erosion and siltation control measures required for this job. If the Contractor desires to stockpile construction materials, stone, earth, etc., the location of same and protection thereof shall be outlined in an Erosion and Siltation Control Plan to be submitted to the Site Engineer for review.
- 3.03 The Contractor shall submit a spill prevention plan to the Site Engineer for review. The contents of this spill prevention plan shall depend on what types of chemicals, lubricants and fuels will be used and if these will be stored on site. As a minimum, if fuel or lubricants or other chemicals are stored on site, either temporarily in vehicular tanks or in skid or trailer mounted tanks, a plan shall be supplied which directs all employees of the Contractor in the proper procedures to be followed should a spill occur. For more complex chemical storage requirements, a more complex plan will be required.
- 3.04 **PRECONSTRUCTION CONFERENCE:** At the Preconstruction Conference, the Contractor shall submit for acceptance his schedule for accomplishment of temporary and permanent erosion control work, as are applicable for clearing and grubbing, grading, bridges, and other structures at watercourses, construction, and paving. He shall also submit for acceptance his proposed method of erosion control on haul roads and borrow pits and his plan for disposal of waste materials. No work shall be started until the erosion control schedules and methods of operations have been accepted by the Site Engineer.
- 3.05 **CONSTRUCTION REQUIREMENTS**
- A. The Site Engineer has the authority to limit the surface area of erodible earth material exposed by clearing and grubbing, the surface of erodible earth material exposed by excavation, borrow and fill operations, and to direct the Contractor to provide immediate permanent or temporary pollution control measures to prevent contamination of adjacent streams or other watercourses, lakes, ponds, or other water impoundment. Such work may involve the construction of temporary berms, dikes, dams, sediment basins, slope drains, and use of temporary mulches, mats, seeding, or other control devices or methods as necessary to control erosion. Cut and fill shall be seeded and mulched as the excavation proceeds to the extent directed by the Site Engineer.

- B. The Contractor shall be required to incorporate all permanent erosion control features into the project at the earliest practicable time as outlined in his accepted schedule. Temporary pollution control measures shall be used to correct conditions that develop during construction that were not foreseen during the preconstruction stage; that are needed prior to installation of permanent pollution control features; or that are needed temporarily to control erosion that develops during normal construction practices, but are not associated with permanent control features on the project.
- C. Where erosion is likely to be a problem, clearing and grubbing operations should be so scheduled and performed that grading operations and permanent erosion control features can follow immediately thereafter if the project conditions permit; otherwise erosion control measures may be required between successive construction stages. Under no conditions shall the surface area of erodible earth material exposed at one time by clearing and grubbing exceed 5,000 linear feet without approval of the Site Engineer.
- D. The Site Engineer will limit the area of excavation, borrow, and embankment operations in progress commensurate with the Contractor's capability and progress in keeping the finish grading, mulching, seeding, and other such permanent pollution control measures current in accordance with the accepted schedule. Should seasonal limitations make such coordination unrealistic, temporary erosion control measures shall be taken immediately to the extent feasible and justified.
- E. In the event of conflict between these requirements and pollution control laws, rules or regulations, or other Federal, State or Local agencies, the more restrictive laws, rules, or regulations shall apply.

3.06 CONSTRUCTION OF STRUCTURES

- A. Temporary Berms
 - 1. A temporary berm shall be constructed or compacted soil, with a minimum width of 24 inches at the top and a minimum height of 12 inches, with or without a shallow ditch, constructed at the top of fill slopes or transverse to centerline on fills. Temporary berms shall be graded so as to drain to a compacted outlet at a slope drain. The area adjacent to the temporary berm in the vicinity of the slope drain must be properly graded to enable this inlet to function efficiently and with only minimum ponding in this area. All transverse berms required on the downstream side of a slope drain shall extend across the grade to the highest point at approximately a ten (10) degree angle with a perpendicular to centerline. The top width of these berms may be wider and the side slope flatter on transverse berms to allow equipment to pass over these berms with minimal disruptions. When practical and until final roadway elevations are approached, embankments should be constructed with a gradual slope

to one side of the embankment to permit the placement of temporary berms and slope drains on only one side of the embankment.

B. Temporary Slope Drains

1. Temporary slope drains shall consist of stone gutters, fiber mats, plastic sheets, concrete or asphalt gutters, half round pipe, metal pipe, plastic pipe, flexible rubber, or other materials which can be used as temporary measures to carry water accumulating in the cuts and on the fills down the slopes prior to installation of permanent facilities or growth of adequate ground cover on the slopes.
2. Fiber matting and plastic sheeting shall not be used on slopes steeper than 4:1 except for short distances of 20 feet or less.
3. All temporary slope drains shall be adequately anchored to the slope to prevent disruption by the force of the water flowing in the drains. The base for temporary slope drains shall be compacted and concavely formed to channel the water or hold the slope drain in place. The inlet end shall be properly constructed to channel water into the temporary slope drain. Energy dissipater would be dumped rock or a small sediment basin which would slow the water as well as pick up some sediment. All temporary slope drains shall be removed when no longer necessary and the site restored to match the surroundings.

C. Sediment Structures

1. Sediment structures shall be utilized to control sediment at the foot of embankments where slope drains outlet; at the bottom as well as in the ditch lines atop waste sites; and in the ditch lines or borrow pits. Sediment structures may be used in most drainage situations to prevent excessive siltation of pipe structures. All sediment structures shall be at least twice as long as they are wide.
2. When use of temporary sediment structures is to be discontinued, all sediment accumulation shall be removed, and all excavation backfilled and properly compacted. The existing ground shall be restored to its natural and intended condition.

D. Check Dams

1. Check dams shall be utilized to retard stream flow or restrict stream flow within the channel. Materials utilized to construct check dams are varied and should be clearly illustrated or explained in the Contractor's erosion control plan.
2. All check dams shall be keyed into the sides and bottom of the channel. A design is not needed for check dams.

E. Temporary Seeding and Mulching: Seeding and mulching shall be performed in accordance with the Section 2.16 - Seeding. Seeding and mulching shall occur as soon as practical after water line installation but no more than 10 working days.

- F. Baled Hay or Straw Erosion Checks or Erosion Wattles or Erosion Control Matting: Hay or straw erosion checks shall be embedded in the ground four (4) to six (6) inches to prevent water flowing under them. The bales and erosion wattles shall also be anchored securely to the ground by wooden stakes driven through the bales into the ground. Erosion control matting shall be pinned to the ground after stretching and placement. Bales and matting shall remain in place until they rot, or be removed after they have served their purpose, as determined by the Site Engineer. The Contractor shall keep the checks in good condition by replacing broken or damaged bales immediately after damage occurs. Normal debris cleanout will be considered routine maintenance.
- G. Temporary Silt Fences
 - 1. Temporary silt fences shall be placed on the natural ground, at the bottom of fill slopes, in ditches, or other areas where siltation is a problem. Silt fences are constructed of wire mesh fence with a covering of burlap or some other suitable material on the upper grade side of the fence and anchored into the soil.
 - 2. The Contractor shall be required to maintain the silt fence in a satisfactory condition for the duration of the project or until its removal is requested by the Site Engineer. The silt accumulation at the fence may be left in place and seeded or removed, as directed by the Site Engineer. The silt fence remains the property of the Contractor whenever the fence is removed.
- H. Under no circumstances shall spent oil wastes be discharged on the site.

3.07 MAINTENANCE

- A. The temporary erosion control features installed by the Contractor shall be acceptably maintained by the Contractor until no longer needed or permanent erosion control methods are installed. Any materials removed shall become the property of the Contractor.

- 3.08 EROSION CONTROL OUTSIDE PROJECT AREA: Temporary pollution control shall include construction work outside the project area where such work is necessary as a result of construction such as borrow pit operations, haul roads, and equipment storage sites.

END OF SECTION

SECTION 2.15

FINISH GRADING

PART 1 – GENERAL

1.01 SECTION INCLUDES

- A. The work called for by this section shall include, but not necessarily be limited to, finish grading and the spreading and shaping of topsoil to the finished contour elevations indicated by the drawings.
- B. Refer to other sections for work related to that specified under this heading. Coordinate this work with that specified by other sections for timely execution.

PART 2 – PRODUCTS

2.01 TOPSOIL

- A. Use stripped topsoil that has been stockpiled as specified elsewhere. If the quantity of topsoil on the job is inadequate, furnish enough additional topsoil at no additional cost to the **District**. Topsoil furnished shall be natural, fertile, friable soil possessing characteristics of representative productive solids in the vicinity. It shall be obtained from naturally well drained areas. It shall not be excessively acid or alkaline nor contain toxic substances that may be harmful to plant growth. Topsoil shall be without admixture of subsoil and shall be cleaned and reasonably free from clay, lumps, stones, stumps, roots, or similar substances 2 inches or more in diameter, debris, or other objects that are a hindrance to planting operations. Such material shall be subject to testing.

PART 3 – EXECUTION

3.01 GRADING

- A. Do not begin work until the earth is dry enough to be tillable.
- B. Inspect subgrades to see that they generally conform to the standards called for elsewhere in these specifications, particularly with regard to the approximate depths required for the work. After work is completed, inspect it to ensure that all finish grading complies with design requirements.
- C. Finish grade all areas to the depths required for the work as follows:
 - 1. Grade uniformly with rounded surfaces at the tops and bottom of abrupt changes of planes.

2. Hand grade steep slopes and areas that are inaccessible for machine work.
 3. Protect graded areas from undue erosion, and repair and regrade areas where erosion does occur.
 4. Refill areas where noticeable settlement has occurred.
 5. Finish grade areas that are to receive topsoil up to 6 inches below the finished contour elevations called for by the drawings or, over rock, to 12 inches below these elevations.
- D. Place topsoil uniformly over disturbed areas that do not receive other work as follows:
1. Scarify subgrade to a depth of 3 inches.
 2. Place the topsoil to a depth of 6 inches when lightly rolled or, on rock, to a depth of 12 inches.
 3. Level the topsoil so that it slopes uniformly and has no water pockets.
 4. Carefully rake the topsoil by hand to remove all clods, roots, sticks, stones over 1 inch in diameter, and other foreign materials from the surface.
- E. Dispose of excess excavated materials and debris away from the site.

END OF SECTION

SECTION 2.16

SEEDING

PART 1 - GENERAL

- 1.01 This work shall be performed in all disturbed areas not receiving such site improvements as buildings, roads, walks, sod, planting, etc., and shall include, but not necessarily be limited to, all seed bed preparation; the supplying and placing of soil additives, seed, and mulch and maintenance.
- 1.02 Refer to other sections for items affecting seeding. Coordinate this work with that specified by other sections for timely execution.

PART 2 – PRODUCTS

2.01 MATERIALS

- A. GRASS SEED: Kentucky 31 Fescue (*Festuca elatior*) and/or annual rye meeting the requirements of the State Department of Agriculture and furnished in new bags or bags that are sound and not mended; no “below standard” seed will be accepted.
- B. FERTILIZER: commercially manufactured; Grade 10-10-10; furnished in standard containers that are clearly marked with the name, weight, and guaranteed analysis of the contents and that ensure proper protection in transportation and handling; and in compliance with all local, state, and federal fertilizer laws.
- C. AGRICULTURAL LIMESTONE: containing a minimum of 85% calcium carbonate and magnesium carbonate combined, 85% of which passes a No. 10 mesh sieve.
- D. MULCH: stalks of rye, oats, wheat, or other approved grain crops properly cured prior to baling, air dried, and reasonably free of noxious weeds and weed seeds or other material detrimental to plant growth.

PART 3 - EXECUTION

3.01 SEEDING

- A. Perform all seeding and related work as a continuous operation. Sow seed as soon as the seed bed has been prepared, and perform subsequent work in a continuous manner. Initial seeding shall occur within 14 days after the trench has been closed.
- B. Before beginning seeding operations in any area, complete the placing of topsoil and final grading.

- C. Scarify, disk, harrow, rake, or otherwise work each area to be seeded until the soil has been loosened and pulverized to a depth of not less than two (2) inches. Perform this work only when the soil is in a tillable and workable condition.
- D. Apply fertilizer and agricultural limestone uniformly over the seed bed, and lightly harrow, rake, or otherwise incorporate them into the soil for a depth of approximately one (1) inch at the following rates:

Fertilizer: 40 pounds per 1,000 square feet
Agricultural Limestone: 80 pounds per 1,000 square feet
- E. Sow seed uniformly with a rotary seeder, wheelbarrow seeder, hydraulic equipment or by other satisfactory means.
- F. The seeding rate shall be five (5) pounds per 1,000 square feet for Kentucky 31 Fescue (*Festuca elatior*) .
- G. For temporary stabilization seeding rate shall be three (3) pounds per 1,000 square feet of annual rye grass.
- H. Perform no seeding during windy weather or when the ground surface is frozen, wet, or otherwise untillable.
- I. When seeding with mulch is specified spread mulch material evenly over the seeded areas immediately following the seeding operation.

Mulch Rate: Two (2) bales (100 pound minimum) per 1,000 square feet
- J. The mulch rate may be varied, depending on the texture and condition of the mulch material and the characteristics of the area seeded. Cover all portions of the seeded areas with a uniform layer of mulch so that approximately 25% of the ground is visible.
- K. No equipment, material storage, construction traffic, etc., will be permitted on newly seeded ground.
- L. Re-seeding shall occur as many times as required to obtain a successful stand of ground cover prior to acceptance by the **District**.
- M. Contactor is responsible for providing irrigation and/or temporary water in order to establish the new replacement seeding. No additional cost will be considered for cost of labor, equipment, materials or water required to establish and maintain seeding until project acceptance.

3.02 INSPECTIONS

- A. The **District** shall inspect the seeding within 60 days after planting and determine if it is acceptable.

3.03 GUARANTEES

- A. Secure an acceptable growth of grass in all areas designated for seeding.
- B. The Contractor is responsible for growth of ground cover until the project has been accepted by the **District** at which time the warranty period will begin. Regardless of weather conditions or season, the Contractor shall obtain a stand of ground cover (excluding weeds and deleterious growth) prior to acceptance by the **District**. NO additional payment will be considered for work required to obtain a satisfactory stand of ground cover regardless of number of seeding and re- seeding applications.

END OF SECTION

SECTION 2.17

BORING AND CASING FOR WATER LINES

PART 1 – GENERAL

1.01 SECTION INCLUDES

- A. The work to be performed hereunder shall consist of the installation of a casing pipe for the purpose of installing water line. It shall include the excavation of a boring pit, auger boring between the points as specified on the drawings, furnishing and installing of the casing pipe and carrier pipe, and disposing of the excavated materials in the manner herein provided.
- B. Water lines crossing beneath existing concrete drives shall be bored. No casing pipe is required for drives. Water line shall be installed beneath drive so that no bell or spigot is located beneath drive.
- C. All crossing of County or State roads shall be installed by bore and jack methods with steel casing unless otherwise approved by the local roadway governing agency.

PART 2 - PRODUCTS

2.01 CASING PIPE

- A. The casing pipe shall be of steel meeting the latest approved American Railway Engineering Association “Specifications” for Pipelines for Carrying Flammable and Nonflammable Substances.” The steel casing pipe shall be a ASTM A252, Grade 2 and shall have a minimum yield strength of 35,000 PSI and shall have the minimum wall thickness shown in the following table:

TABLE OF MINIMUM WALL THICKNESS FOR STEEL CASING PIPE FOR E72 LOADING

<u>Carrier Pipe Diameter</u>	<u>Casing Pipe Diameter</u>	<u>Nominal Thickness (including coating)</u>
4 inches	8 inches	0.250 inches
6 inches	12 inches	0.250 inches
8 inches	16 inches	0.312 inches
10 inches	20 inches	0.312 inches
12 inches	24 inches	0.312 inches
16 inches	28 inches	0.375 inches
18 inches	30 inches	0.406 inches
20 inches	36 inches	0.500 inches

- B. When the casing pipe is installed without benefit of a protective coating, the wall thickness shown above shall be increased to the nearest standard size, which is a minimum of 0.063 inches greater than the thickness shown.

2.02 CARRIER PIPE

- A. The carrier pipe shall be ductile iron pipe CL 52 thickness.

2.03 CASING SPACERS

- A. Casing spacers shall be provided for carrier pipe. Spacing shall be at the midpoint and at 1 foot from each side of joint (3 per pipe segment). Spacers shall be sized to eliminate movement of pipe inside the casing.
- B. Casing spacers shall be all non-metallic, virgin polypropylene, molded in segments for field assembly without any special tools. Spacer segments shall be secured around the carrier pipe. The casing spacer polymer shall contain UV inhibitors and shall have a minimum compressive strength of 3,000 psi, and 800 volts/mil dielectric strength and impact strength of 1.5 ft-lbs./inch. Each casing spacer shall have full length integrally molded skids extending beyond the bell or mechanical joint of the pipe. Spacers shall be at least 6.5 inches in width. Casing spacers shall be Ranger II Model by GPT of Houston, TX or equal.

2.04 END SEALS

- A. A wrap-around self-sealing 1/8" thick synthetic rubber end seal shall be applied to each end of the casing pipe. End seals shall be Type W by GPT or equal.

PART 3 - EXECUTION

3.01 GENERAL REQUIREMENTS

- A. Perform all crossings according to the requirements of the governing highway department or railroad company permit documents. No work may proceed if the appropriate permit has not been obtained. The DISTRICT shall be provided with a copy of each crossing permit at the time of the pre-construction meeting..
- B. Notify the appropriate authorities involved and request their supervisory services during construction.
- C. Provide necessary safeguards to protect the crossing.

3.03 INSTALLATION OF CASING PIPE

- A. If required to bore and jack casing pipe, this shall be accomplished by means of dry auguring to the size, line, and the grade shown on the drawing. No wet jetting or wet augering of casing shall be employed. Jack the steel casing pipe into place

as the boring proceeds. Weld sections of casing pipe together with continuous welds to provide watertight joints. Tack welding of casing will not be permitted

- B. If casing pipe is installed via open cut method, install the casing pipe using backfill requirements set forth in Section 3.01. Provide continuous welds to weld sections of casing pipe together to provide watertight joints.
- C. Casing that is not in the correct vertical and horizontal alignment will not be accepted. When viewing the completed casing from one end, a casing installation shall be considered acceptable if a full circle is viewable at the opposite end.
- D. Do not remove unacceptable casing without prior approval from the District. If the removal of casing pipe is permitted, make proper provisions to prevent caving in of the earth surrounding the casing. Void spaces shall be filled with grout or flowable fill. At a minimum, abandoned bore holes shall be pumped full with grout or flowable fill.

3.04 INSTALLATION OF CARRIER PIPE

- A. The carrier pipe shall be furnished by the Contractor. Upon acceptance of the casing, install the carrier pipe in the casing by jacking it through the casing. Achieve proper line and grade on the carrier pipe, by use of the casing spacers.
- B. Test the carrier pipe in accordance with Section 3.01, Water Lines.
- C. Alignment and grade shall be installed and maintained per the contract drawings.
- D. No wood blocking of carrier pipe will be permitted.
- E. Upon completion of installing carrier pipe in casing pipe, seal both ends with end seals.

3.05 LAYOUT OF WORK

- A. The Contractor will provide all detailed layout required to keep the bore on correct grade and alignment.

3.06 GUARANTEE OF WORK

- A. Guarantee a usable completed casing between the points specified and to the line and grade specified. The allowable tolerance at the downstream end point of the bore shall be such that the invert of the carrier pipe may be positioned within a vertical area limited on the top by an elevation no higher than the elevation shown on the drawings and on the bottom by an elevation no lower than the existing inlet pipe invert.
- B. Any failed casing installation due to misalignment or boring equipment failure shall be corrected to the satisfaction of the appropriate permit holder. Contractor

shall communicate and be granted approval of their means and methods of rescuing failed equipment (e.g., stuck or jammed bore head) as may be required by the permitting authority. The Contractor shall bear all costs for these corrective efforts at no additional cost or liability to the DISTRICT.

- C. The allowable tolerance at the upstream end point of the bore shall be such that the invert of the carrier pipe may be positioned at the elevation shown on the drawings.

END OF SECTION

SECTION 3.01

WATER LINES

PART 1 GENERAL

1.01 SECTION INCLUDES

- A. Any Contractor that is undertaking a project with public water improvements that are to become a part of the Gladeville Utility **District** water system shall possess and maintain an active contractor's license in the State of Tennessee. The contractor shall have an active BC, BC-B, MU-B, or MU-A.3 license. The contractor will be required to present evidence of licensure at the pre-construction meeting for each project they are to be engaged upon.
- B. Contractor shall be responsible for safely storing materials needed for work that have been accepted by him until they have been incorporated into the completed project. Keep the interiors of all pipes, fittings, and other accessories free from dirt and foreign matter at all times.
- C. Trenching includes excavating, backfilling, compacting, disposing of surplus material, and all other work incidental to the construction of trenches for utilities and buried appurtenances, including additional excavation which may be required for structures forming a part of the pipe line.
- D. Excavation shall be considered unclassified and includes removal of quicksand, hardpan, boulders, rock, clay, rubbish, unforeseen obstacles, underground conduits, pipe, drain tile, trees, root, timber or masonry structures, pavements, sidewalks, and all other obstacles encountered.
- E. Joint restraint devices are required at all fittings. Where soil is not suitable to provide stability for reaction blocking or where site condition constraints do not allow physical space for reaction blocking, all fittings, appurtenances and valves must still be restrained with restraint devices. Reaction blocking may be allowed if adequate stability for placement of concrete is present.

1.02 RELATED SECTIONS

- A. Section 1.00 Design Criteria and Technical Requirements
- B. Section 2.12 Trenching, Backfilling and Compaction for Utilities
- C. Section 2.13 Unclassified Excavation for Utilities
- D. Section 3.02 Water Valves, Hydrants, and Appurtenances

PART 2 PRODUCTS

2.01 DUCTILE IRON PIPE AND FITTINGS

- A. Ductile iron pipe shall be centrifugally cast in metal or sand-lined molds and shall conform to the specifications of ANSI A21.51/AWWA C151. The pipe shall have a minimum wall thickness conforming to Thickness Class 52 or heavier. All pipe shall be new and manufactured in the U.S.A. by American Cast Iron Pipe Company; U.S. Pipe; or McWane.
- B. Pipe shall be furnished in nominal lengths of 18' or 20' and the nominal length of each individual piece of ductile iron pipe shipped must be plainly marked on that piece of pipe.
- C. The push-on, single gasket joints shall be either Fastite (manufactured by American Cast Iron Pipe Company), Tyton (U.S. Pipe), or other joints of similar type and equal quality. They shall be able to withstand 350 psi of operating pressure.
- D. Restrained joint pipe where noted on plans shall be American Flex-Ring®, US Pipe TR Flex® or McWane/Clow Super-Lock pipe.
- E. Where note on the drawings for the use of restrained joint pipe, restrained joint pipe may also be accomplished by the use of gripper-style gaskets. Gripper style restraint gaskets shall be Fast-Grip® by American Cast Iron Pipe Co., Field-Lok 350® by US Pipe Co., or Sure Stop 350® by McWane Pipe Co.
- F. The bell of each pipe shall have a tapered annular opening and a cast or machined retaining groove for the gasket. The gasket groove shall have a flared design so that maximum deflection will be provided. The plain spigot end of the pipe shall be beveled in order to simplify its entry into and centering within the bell and the compression of the gasket.
- G. The gasket shall be of high-quality vulcanized rubber made in the form of a solid ring to exact dimensions. The design of the gasket groove in the bell of the pipe and the design, hardness, and other properties of the gasket itself shall be such that the joint is liquid tight for all pressures from a vacuum to a maximum rating of 350 psi of internal liquid pressure.
- H. Enough lubricant shall be furnished with each order to provide a thin coat on the spigot end of each pipe. This lubricant shall be nontoxic, impart no taste or smell to the water, and have no harmful effect on the rubber gasket. It shall have a consistency that will allow it to be easily applied to the pipe in either hot or cold weather. (If pipe or fittings are installed in a submerged or

extremely wet environment, “underwater” or “non-soluble” lubricant shall be used.)

- I. Fittings shall be ductile iron in accordance with ANSI/AWWA C153/A21.53, latest revisions. Mechanical joint fittings will require the use of mechanical restraint devices such as EBAA MegaLug restraints, MJ FieldLok restraints by US Pipe or Union Foundry, Sigma One-Lok restraints or approved equal.
 - J. Internal and External Pipe Coatings
 - 1. Pipe and fittings for buried water lines shall be lined with cement lining as specified in ANSI A21.4/AWWA C104. In addition, a bituminous seal coat or asphalt emulsion spray coat approximately one (1) mil thick may be applied to the cement lining in accordance with the pipe manufacturer’s standard practices. The pipe and fittings shall be furnished with a bituminous coating on the outside.
 - K. Poly-wrapping: Polyethylene tubing and tape shall meet the requirements of AWWA C105/ANSI A21.5
 - L. The pipe manufacturer shall furnish a notarized certificate stating that pipe furnished has been manufactured and tested in accordance with the applicable standards.
 - K. Field Cuts of Pipe: Field cuts are allowed to meet field conditions. All field cuts shall be in accordance with the pipe manufacturer recommendations. Field cut ends shall be beveled to prevent damage to gaskets.
- 2.02 MECHANICAL JOINT RESTRAINT DEVICES (LUG-STYLE) FOR FITTINGS AND VALVES NOT ADJACENT TO FITTINGS
- A. Mechanical Joint Restraint Devices:
 - 1. Restraint devices shall consist of multiple gripping wedges incorporated into a follower gland meeting the requirements of ANSI/AWWA C110/A21.10.
 - 2. Devices shall have a working pressure rating of 350 psi for 3 – 16 inch and 250 psi for 18 inch and larger. Ratings are for water pressure and must include a minimum safety factor of 2:1.
 - 3. Restraint devices shall have torque bolts.
 - 4. Megalug Series 1100 produced by EBAA Iron, Inc., Ford Series 1400, MJ FieldLok, U.S. Pipe or Union Foundry, SIGMA One-Lok or approved equal.
 - B. Restraint Devices - General:

1. Gland body, wedges and wedge activating components shall be cast from grade 65-45-12 ductile iron material in accordance with ASTM A536.
2. Installation shall be performed using conventional tools and installation procedures per AWWA C600 while retaining full mechanical joint deflection during assembly as well as allowing joint deflection after assembly.
3. Proper activation of the gripping wedges shall be ensured with torque-limiting twist-off nuts.

2.03 MJ RESTRAINT FOR SYSTEM VALVES CONNECTED TO FITTINGS

- A. Either style may be used depending on valve size.
- B. BOLT-THROUGH STYLE (3-INCH – 12 INCH)
 1. Mechanical joint valves shall be connected to fittings using a bolt-through positive restraint mechanism manufactured of ductile iron conforming to ASTM A536-65-45-12. The positive restraint device shall connect the valves and corresponding fittings at a linear distance not to exceed three (3) inches and without attachment to the pipe. The device shall come complete with all accessories, including standard styrene butadiene rubber (SBR) MJ gaskets conforming to the latest revision of AWWA C111/ASTM F-477 and weathering steel (Corten) bolts conforming to AWWA C111/A21.11 and ASTM A242. Nuts for 3 through 12-inch sizes shall be SAE Grade 5 steel with black oxide coating. Nuts for 14-inch and larger adaptors shall be heavy hex Corten steel conforming to ASTM A242. Sizes 3-12 inch of the bolt-through MJ positive restraining device shall be supplied with NSF-61 asphaltic seal, coating in accordance with ANSI/AWWA C104/A21.4. This device is not allowed for sizes 14-26-inch. The device shall be used with standard mechanical joint fittings (AWWA C110 or C153) and valves. The device shall be a Foster Adaptor, Flex T-2, or Flex T-3 (dependent upon application) furnished by Infact Corporation or approved equal.
- C. FABRICATED SWIVEL ANCHOR COUPLINGS FOR SYSTEM VALVES CONNECTED TO FITTINGS (3-INCH AND LARGER)
 1. Anchor swivel couplings shall be made of Ductile Iron Pipe Class 53.
 2. 14”– 24” MJ anchor swivel couplings are to be pressure rated at 350 psi.

3. Above materials shall meet all applicable sections of A.N.S.I. A21.10, A21.15, A21.50, A21.51, B2.1, B16.1/ A.W.W.A. C110, C115, C150, C151, and all revisions thereto.
4. Lining shall be in accordance with A.N.S.I. A21.4., AWWA C104 Mechanical Joint Gland A.N.S.I. / A.W.W.A. A21.10 / C110, A21.53 / C153.
5. Tolerance on lengths of anchor couplings shall be 0.25”.
6. Length of anchor swivel couplings shall not exceed five feet.

PART 3 EXECUTION

3.01 PIPE LINE LAYOUT & EASEMENT STAKING

- A. Prior to commencement of pipe laying, if an easement exists then both sides of the permanent Gladeville Utility **District** easement shall be staked. Visible evidence of staking shall be placed at a minimum of 50-foot intervals with proposed grades marked on each stake. In the event of loss or damage of the easement staking, these shall be replaced by the Contractor to ensure pipe installation remains within the easement.
- B. Contractor shall strictly maintain the horizontal alignment of the pipe as shown on the drawings. Deviation of the alignment shall be done only with the approval of the Gladeville Utility **District** and its Engineer. The centerline of the proposed water line shall be staked at 50’ intervals with proposed grades marked on each stake.
- C. The surveyor shall provide **District** with a letter certifying the easement and pipe alignment have been properly staked. Surveyor shall be licensed in the State of Tennessee.
- D. Before pipe laying can commence, all onsite sanitary sewer and storm sewer installation must be complete.

3.02 PIPE STORAGE

- A. Pipe shall be stored with both ends of each pipe section temporarily sealed to prevent debris or animals from entering pipe sections.
- B. Stacked pipe shall be secured to prevent accidental movement or shifting of pipe.

3.03 EXCAVATION FOR PIPELINE TRENCHES

- A. Excavation for pipelines shall consist of the excavation necessary for the construction of water lines and their appurtenances (including valves, fittings, collars, concrete saddles, and pipe protection) that are called for by the

drawings. It shall include clearing and grubbing where necessary, backfilling and tamping pipe trenches and around structures, and disposing of waste materials, all of which shall conform to the applicable provision set forth elsewhere in these specifications.

- B. The Contractor may, if he chooses, use a motor-powered trenching machine. If he does, however, he shall be fully responsible for the preservation or repair of existing utility service connections.
- C. Unless the construction of lines by tunneling, jacking or boring is called for by the drawings or specifically authorized by the Engineer, make excavation for pipelines in open cut and true to the lines and grades shown on the drawings or established by the Engineer on the ground. Cut the banks of trenches between vertical parallel planes equidistant from the pipe centerline. The horizontal distance between the vertical planes (of, if sheeting is used, between the inside faces of that sheeting) shall vary with the size of the pipe to be installed, but shall not be less than the distance determined by the following formula: (outside diameter of pipe + 36"). The banks of trenches from the ground surface down to a depth not closer than 1' above the top of the pipe may be excavated to a non-vertical and non-parallel planes, provided the excavation below that depth is made with vertical and parallel side equidistant from the pipe centerline in accordance with the parameters given above. Any cut made in excess of the maximum depth shall be at the expense of the Contractor and may be cause for the Engineer to require that stronger pipe and/or higher class of bedding be used at no cost to the **District**.
- D. For all pipe in non-rock trenches, shape the bottom of all trenches to provide uniform bearing for the bottom of the pipe barrel.
- E. Excavate bell holes for bell and spigot pipe at proper intervals so that the barrel of the pipe will rest for its entire length upon the bottom of the trench. Bell holes shall be large enough to permit proper jointing of the pipe. Do not excavate bell holes more than ten joints ahead of pipe laying.
- F. Do not excavate pipe trenches more than two hundred (200) feet ahead of the pipe laying, and not more than two hundred (200) feet of open ditch shall be left behind the pipe laying, and perform all work so as to cause the least possible inconvenience to the public. Construct temporary bridges or crossings when and where the Engineer deems necessary to maintain vehicular or pedestrian traffic.
- G. In all cases where materials are deposited along open trenches, place them so that in the event of rain no damage will result to the work and/or to adjacent property.

3.04 INSTALLATION OF WATER LINES

- A. Lay water lines to maintain grades required by the drawings. All fittings, valves, and hydrants shall be at the required locations, the spigots centered in the bells, and all valves and hydrant stems plumb.
- B. Unless otherwise indicated by the drawings, all water pipes shall have at least 36 inches of cover or 42 inches when inside roadways and paved areas. No departure from this policy shall be made except with the approval of the Engineer.
- C. Unless otherwise noted on the plans, restrained joint pipe may be accomplished by the use of restrained joint pipe and fittings as set forth in Paragraph 2.01.D. Foster adaptors or approved equal bolt-through positive mechanical joint restraint mechanisms shall be utilized at all connections between a fitting and adjoining gate valve(s).
- D. Provide and use tools and facilities that are satisfactory to the Engineer and that will allow work to be done in a safe and convenient manner. All pipe, fittings, valves, and hydrants are to be unloaded from the trucks using suitable tools and equipment. Use suitable equipment, straps and tools to lower all pipe, fittings, valves, and hydrants into the trench one (1) piece at a time. Lower each piece carefully so that neither it nor any protective coating or lining it may have shall be damaged. Under no circumstances drop or dump water line materials into the trench.
- E. Any pipes strung out along the route of the proposed lines before the actual installation of those lines is due to take place shall not be lowered into the trench until they have been swabbed to remove any mud, debris, etc., that may have accumulated within them. Remove all unnecessary material from the bell and spigot end of each pipe. Before any pipe is laid, brush and wipe clean the outside of its spigot end and the inside of its bell, and leave dry and oil-free.
- F. Take every precaution to keep foreign material from getting into the pipe while it is being placed in the line. If the crew laying the pipe cannot put it into the trench and in place without allowing earth to get inside, then place a heavy, tightly woven canvas bag or plug of suitable size over each end of the pipe, and leave in place until it is time to connect that pipe to the adjacent pipe.
- G. Place no debris, tools, clothing, or other materials in the pipe during laying operations.
- H. After a length of pipe has been placed in the trench, center the spigot end in the bell of the adjacent pipe, and insert to the depth specified by the

manufacturer and bring to the correct line and grade. Secure the pipe in place by tamping an approved backfill material around it.

- I. Bell holes shall be large enough so that there is ample room for the pipe joints to be properly made. Between bell holes, carefully grade the bottom of the trench so each pipe barrel rests on a solid foundation for its entire length.
- J. Whenever pipe laying is not in progress, close the open ends of pipe either with a watertight plug or by other means approved by the Engineer. If there is water in a trench, leave this seal in place until the trench has been pumped completely dry.
- K. Cut pipe so that valves, fittings, or closure pieces can be inserted in a neat workmanlike manner without any damage to the pipe. Follow the manufacturer's recommendations concerning how to cut and machine the ends of the pipe in order to leave a smooth end at right angles to the pipe's axis.
- L. Lay pipes with the bell ends facing in the direction of laying unless otherwise directed by the Engineer or District.
- M. Wherever pipe must be deflected from a straight line (in either the vertical or horizontal plane) in order to avoid obstructions or plumb stems, or wherever long radius curves are permitted, the amount of deflection shall not exceed that necessary for the joint to be satisfactorily made, nor that recommended by the pipe manufacturer, and shall be approved by the Engineer.
- N. Lay no pipe in water or when it is the Engineer's opinion that trench conditions are unsuitable. If crushed stone is used to improve trench conditions or as backfill for bedding the pipe, its use is considered incidental to the project, and no separate payment will be made for its use.
- O. Where a water line crosses over a sanitary sewer, use a full joint of pipe with a standard push-on, restrained or mechanical joint, and centered over the sewer so that joints will be equidistant and as far as possible from the sewer. Provide adequate structural support for the sewers to prevent excessive deflection of joints and settling on and breaking the water line. Where a water line is to be parallel to a sanitary or storm sewer, lay it at least ten (10) feet from the sewer. If it is not practical for the water and sewer lines to be separated as described above, then lay the water line so that the bottom of the water line is at least 18 inches above the top of the sanitary sewer. Where the vertical separation cannot be maintained, the sanitary sewer shall be constructed of material and with joints that are equivalent to water main standards of construction and each utility line shall be pressure tested to assure water-tightness prior to backfilling. Where storm drainage lines exist or are proposed, a minimum of ten (10) feet horizontal separation must be

maintained with the water line. At crossing points of a storm sewer, a minimum of 18 inches of vertical separation must be maintained.

- P. Where a water line passes beneath a sanitary sewer, storm sewer or drainage line, a minimum of 18 inches of separation shall be maintained between the invert of the sewer line and the top of the water line. The bedding and backfill around the water line shall be No. 67 stone or flowable fill for the total distance between the two lines. This special backfilling shall be accomplished in order to maintain adequate structural support for the sewer line and to prevent settlement/sagging of the sewer line or placement of excessive loading on the water line. During installation of the water line beneath the sewer line, the sewer line shall be temporarily supported by straps, chains, beams, equipment or other contractor derived methods to support the sewer line to prevent sagging while water line is being installed. The temporary support shall remain in place until the backfilling of the water line has progressed to the invert of the sewer line at which time it can be removed.
- Q. Where a ductile iron water line is within 10 feet of a steel gas line, the ductile iron water line shall be wrapped with polyethylene encasement (minimum 8 mil thickness) in accordance with ANSI A21.5/AWWA C105. Encasement shall extend 10 feet either side of a crossing and longitudinally for as long as the two pipelines remain in parallel.
- R. Joint all pipe in the exact manner specified by the manufacturer of the pipe and jointing materials. The minimum length of pipe to be used shall be 10 feet unless otherwise shown on construction drawings.
- S. Connecting to Existing Lines
1. Connections of new lines to existing lines shall be as shown on the Plans and/or directed by the Engineer. Notify the **District** not less than 7 days prior to making proposed connection and the actual time of the service interruption shall be subject to the approval by the **District**.
 2. The Contractor shall be completely responsible for determining existing pipeline materials, ordering proper fittings for the connection, and making the connection in an approved manner.
- T. Use of Sleeves
1. Mechanical joint sleeves may be used to facilitate connection of new water lines to existing water lines, existing valves, existing tees, etc.
 2. If approved by the **District** and the District Engineer, a mechanical joint sleeve may be used to repair a leak in the event a leak is the result of a rolled or defective pipe gasket. However, only one (1) sleeve is permitted every 2,500 feet of newly installed water line. If the water line fails to pressure test and multiple (more than 1) pipe defects are evident, then the defective line shall be removed and re-installed to such a point extending to a valve or other fitting in the water line.

3. The use of sleeves to facilitate pipe installation by the Contractor skipping from location to location to avoid rock, etc. is prohibited. The **District** will not accept the use of multiple sleeves for ease of pipeline installation due to ground conditions.

3.05 BEDDING AND BACKFILLING

- A. Do not begin backfilling before the Engineer has inspected the grade and alignment of the pipe, the bedding of the pipe, and the joints between the pipe. If backfill material is placed over the pipe before an inspection is made, reopen the trench in order for an inspection to be made.
- B. Initial bedding from a point 12 inches below the pipe to a point 12 inches over the top of the pipe shall be No. 67 stone. Placement of this stone backfill around the pipe shall be carefully placed with special attention to insuring adequate placement of stone around the lower haunches of the pipe.
- C. In roadway or paved areas, initial bedding from a point 12 inches below the pipe to the top of the ditch shall be No. 67 stone.
- D. From 12 inches above the top of the pipe, perform final backfilling depending upon the location of the work and danger from subsequent settlement. Where pipe is located inside paved roadway or paved areas, final backfilling shall be with No. 67 stone. In roadway areas, cap the top 8 inches of the trench with compacted crusher run roadway base stone.
- E. Backfilling in Unimproved or Easement Areas:
 1. Dispose of and replace all soft or yielding material which is unsuitable for trench backfill with suitable material.
 2. Deposit backfill to the surface of the ground by dragline, bulldozer, or other suitable equipment in such a manner so as not to disturb the pipe. Backfill material may contain broken stones that make up approximately 1/2 of the backfill's total volume. However, if this type of backfill is used, there must be enough spalls and earth materials to fill all voids completely. The maximum dimension of individual stones or rock in such backfill shall not exceed 6 inches. The backfill material shall be tamped and thoroughly compacted in layers equal to compacted density equivalent to that of adjacent earth material. Use special care to prevent the operation of backfilling equipment from causing any damage to the pipe.
 3. Wherever excavation has been made and/or areas disturbed within easements across private property, the top 6 inches of backfill material shall consist of topsoil free from large clods, vegetable

- matter, debris, roots, stone, and/or other objectionable materials. Clay, red dirt, etc. will not be allowed as top coat material.
4. Dispose of all surplus excavated material and remove from the site.
 5. Prior to final acceptance, remove all mounds or restore any settled areas to the elevation of the surrounding terrain.
- F. If earth material for backfill is, in the opinion of the District, too dry to allow thorough compaction, then add enough water so that the backfill can be properly compacted. Do not place earth material the District considers too wet or otherwise unsuitable.
- G. Perform backfilling so as not to disturb or injure any pipe and/or structure against which the backfill is being placed. If any pipe or structure is damaged and/or displaced during backfilling, open up the backfill and make whatever repairs are necessary.
- I. Backfilling and clean-up operations shall closely follow pipe laying; failure to comply with this provision will result in the Engineer's requiring that the Contractor's other activities be suspended until backfilling and clean-up operations catch up with pipe laying.
- J. Pipe fitting restraint:
1. All vertical and horizontal fittings shall be restrained as shown on the drawings.
 2. Fittings may be push-on restrained joint or mechanical joint as set forth in Paragraph 2/01.I of this section.
 3. Push-on restrained joint fittings do not require a concrete thrust block to be poured, unless required by the **District**.
 4. All mechanical joint fittings require the use of restraint devices as set forth in Paragraph 2.02 of this section using lug-style restraint devices.
 5. Bolt-through positive mechanical joint restraint mechanisms shall be utilized in locations where gate valves are to be placed immediately adjacent to the fitting for valve sizes 3" – 12". Refer to Paragraph 2.03.
 6. Fabricated swivel anchor coupling restraint devices shall be used in conjunction with lug-style restraint devices for pipe 14" and larger. These couplings shall not exceed 5-feet in length. Refer to Paragraph 2.04.
 7. Pipe that is indicated to be restrained shall be as specified in Paragraph 2.01 D or 2.01E of this section.
 8. Where required by the **District**, concrete thrust blocks shall be poured in place and shall conform to details and minimum bearing areas as shown in the Standard Details and shall bear against undisturbed trench face. Concrete used in the thrust blocks shall have a minimum compressive strength of 3,000 psi.

7. Fittings shall be protected with polyethylene encasement (minimum 8 mil thickness) when pouring concrete to prevent covering bolts on fittings and restraint devices.

3.06 TEMPORARY TEST TAPS

- A. Temporary test taps may be installed at the direction and approval of the **District** for use in flushing water or removing trapped air. At a minimum, the test tap is to be 1-inch with a direct tapped corp stop followed by PEX piping and a ball valve for control. At the end of the flushing/air expulsion effort, the temporary test tap shall be removed and the corp stop closed.

3.07 AIR RELEASE VALVES

- A. Air release valves shall be placed and sized and shown on the drawings and in accordance with the Standard Details. Air release valves shall be placed at high points along the line route if no fire hydrant is already located at the high point. The **District** reserves the right to add, move or delete an air release valve if the terrain and/or the pipe layout so dictates.

3.08 PRESSURE & LEAKAGE TESTS

- A. After pipe has been laid and backfilled as specified above, subject all newly laid pipe or any valved section thereof to a pressure of 200 psi. Fill line with water 24 hours prior to conducting the pressure tests to allow for removal of any trapped air.
- B. Slowly fill each valved section of pipe with water, and apply the specified test pressure (based on the elevation of the lowest point of the line or section under test and corrected to the elevation of the test gauge) with a pump connected to the pipe in a manner satisfactory to the **District**. Contractor shall furnish the pump, pipe, connections, gauges, and all necessary apparatus.
- C. Conduct a pressure test for at least two (2) hours. All pressure testing shall be conducted using water. **No air testing will be allowed for safety reasons.**
- D. Before applying the specified test pressure, expel all air from pipe. If hydrants or blowoffs are not available at high places, make the necessary taps at the points of highest elevation before testing, and close taps after the test has been completed. No additional payment will be made for taps to remove air or facilitate flushing.
- E. Carefully examine all exposed pipes, fittings, valves, and hydrants during the test. Remove any cracked or defective pipes, fittings, rolled or defective gaskets, valves or hydrants and visible leaks discovered in consequence of this

pressure test, and replace with sound material in the manner specified. Contractor shall repair joints, retighten the bolts, relay the pipe or replace the pipe until the leak is eliminated – regardless of the total leakage as shown by the hydrostatic test. Polyethylene wrapping damaged from repairs must also be properly repaired or replaced at the contractor’s expense. Repeat the test until the results are satisfactory to the **District**.

- F. Properly installed ductile iron pipe should be bottle-tight (no leaks). The Leakage allowance covers factors like air entrapment, pipe expansion and absorption by the cement pipe lining. No pipe installation will be accepted if the leakage is greater than that determined by the formula for ductile iron pipe. The formula for ductile iron pipe leakage testing is:

$L = SD\sqrt{P} / 148,000$ where:

L = allowable leakage in gallons/hr
 S = length of line tested in feet
 D = nominal diameter in inches
 P = average test pressure

3.09 DISINFECTION

- A. All chlorination disinfection and bacteriological procedures shall be in accordance with the latest requirements of the Tennessee Department of Environment and Conservation.
- B. During construction, take precautions to protect pipe interiors, fittings, and valves against contamination. When pipe laying is not in progress (e.g., at the end of the day’s work), place watertight plugs in the ends of all pipe already in the trench; if water accumulates in the trench, leave the plugs in place until the trench is dry. Complete the joints of all pipe in the trench before stopping work for any reason.
- C. Prior to placing the installed water line in service, the new pipe and all exposed sections and appurtenances of existing pipelines shall be cleaned and disinfected with the granular method in accordance with ANSI/AWWA C651-current edition, unless otherwise specified. Pipelines shall be flushed following completion of disinfecting procedures. Disposal or neutralization of disinfection water shall comply with applicable regulations.
- D. While the chlorine is being applied, manipulate valves so that the treatment dosage will not flow back into the line that is supplying the water. Continue the application of chlorine until the entire line being treated is filled with the chlorine solution. Then retain the chlorinated water in the line for at least 24 hours, during which time all valves and hydrants in the line being treated shall be operated so that appurtenances can also be disinfected. After 24

hours, the treated water shall have a chlorine concentration of at least 0.5 mg/l throughout the line.

- E. Final flushing shall be conducted in accordance with AWWA C651-14. After applicable retention period, flush heavily chlorinated water from line until chlorine concentration in water leaving the main is no higher than that generally prevailing in the system, or less than 1.0 mg/L. Perform such flushing only at approved sites. If no approved point of discharge is available, neutralizing chemicals must be applied to the water in order to neutralize the chlorine residual. The amount of chemicals required to neutralize various residual chlorine concentrations in 100,000 gallons of water are shown in Table 1.

TABLE 1 Amounts of Chemicals Required to Neutralize Various Residual Chlorine Concentration in 100,000 Gallons of Water									
Chemical Required									
Residual Chlorine Concentration	Sulfur Dioxide (SO ₂)		Sodium Bisulfite (NaHSO ₃)		Sodium Sulfate (Na ₂ HSO ₃)		Sodium Thiosulfate (Na ₂ S ₂ O ₃ ·5H ₂ O)		
	mg/L	lb.	(kg)	lb.	(kg)	lb.	(kg)	lb.	(kg)
1	0.8		(.36)	1.2		(.54)	1.4		(.64)
2	1.7		(.77)	2.5		(1.13)	2.9		(1.32)
10	8.3		(3.76)	12.5		(5.67)	14.6		(6.62)
50	41.7		(18.91)	62.6		(28.39)	73.0		(33.11)
	60.0		(27.22)						

- F. The velocity of the water used to flush a line shall be at least 2.5 fps. The flow rates required to produce this velocity in various sizes of pipe are shown in the following Table 2:

TABLE 2 REQUIRED OPENINGS TO FLUSH PIPELINES (40 PSI RESIDUAL PRESSURE)					
Pipe Size (inches)	Flow Required to Produce 3.0 fps Velocity (gpm)	No. of Taps on Pipe	Size of Tap	Hydrant Outlet Nozzles	
4	120	1	1"	1	
6	260	1	1-1/2"	1	2-1/2
8	470	3	2 @ 1-1/2"	1	2-1/2
10	730	5	3 @ 1-1/2" 2 @ 2"	1	2-1/2
12	1,060	3	2"	1	2-1/2
16	1,880	5	2"	2	2-1/2
18	2,850	3	2"	1	4-1/2

- G. Once a line has been flushed, test to make certain that the residual chlorine in the water is within acceptable limits.
- H. It must be noted that flushing is no substitute for taking preventative measures before and during the laying of water lines. Certain contaminants - - especially those in caked deposits-- are difficult or even impossible to remove by flushing, no matter how high the velocity. Furthermore, in pipes with diameters of 16 inches or more, it can be difficult to achieve even the minimum recommended flushing velocity of 3.0 fps. Where such stated flow rates are not possible, flushing at the maximum expected flow rate for the line for 2-3 volumes may be acceptable with prior approval of the **District**. Other options such as pigging may be acceptable with prior approval of the **District**.

3.10 BACTERIOLOGICAL TESTS

A. Sampling Protocol:

1. Install the water line(s) with designated amount of chlorine.
2. Contractor shall coordinate with the **District** to fill the water line with water from a test jumper with appropriate backflow device. (No direct connections to existing mains are allowed).
3. The **District** will check the new line(s) for chlorine residual of at least 50 mg/l. Contractor shall provide sample test points as needed to allow for testing. Sample test points are not a separate pay item.
4. Highly chlorinated water shall reside in the new line for a minimum of 24 hours.
5. After 24 hours, the new line shall have a minimum of 0.5 mg/l chlorine residual and then shall be flushed to a level of normal system chlorine residual. Final flushing and disposal of heavily chlorinated water shall be neutralized prior to discharge as noted above in Table 1.
6. The new line shall be allowed to sit for 48 hours.
7. After 48 hours, bacteriological samples shall be collected by the **District** at every 1,200 linear feet of the line in accordance AWWA C651 (including beginning and end) and at the ends of all lines/laterals less than 1,200 linear feet. Collected samples shall be delivered to the **District's** laboratory for testing. No bacteriological sampling will be conducted on or prior to a **District** observed holiday.
8. New lines may be released for service connection upon laboratory results indicating "NEGATIVE" results for coliform.

3.11 DISINFECTION PROCEDURE AFTER CUTTING INTO OR REPAIRING EXISTING LINES

- A. The procedures outlined above apply primarily to cases in which the lines are wholly or partially dewatered.

- B. For leaks or breaks that are repaired with clamping devices while the lines remain full of water under pressure at all times, disinfection and/or testing may not be required.
- C. When an existing line is opened, whether by accident or design, the excavated area could be wet and contaminated because of the presence of sewers nearby. The danger of contamination from such pollution can be lessened if liberal quantities of hypochlorite are applied to the open trenches. It is better to use tablets for disinfection in such cases because they dissolve slowly and continue to release hypochlorite as water is pumped from the excavation site.
- D. Where practical, treat the lines by the slug method in accordance with AWWA C651.
- E. The following disinfection procedure is considered the minimum that may be used when existing lines are repaired:
 - 1. Swab the interior of all pipes and fittings (particularly couplings and tapping sleeves) that are to be used in repairing an existing line with a solution of 65% hypochlorite before installing them.
 - 2. The most practical means of removing contamination introduced into a line during repairs is to give the line a thorough flushing. If the locations of valves and hydrants make it possible, flushing in both directions is recommended. Start flushing as soon as repairs are completed, and continue until all discolored water is eliminated.
- F. Bleach shall be concentrated conventional bleach product. Outdoor bleach cannot be used for disinfection procedures.

3.12 FINAL WATER LINE ACCEPTANCE

- A. Until water line has received final acceptance for service, all fire hydrant assemblies shall remain covered with plastic bag. Remove bags from hydrants after final water line acceptance.
- B. After completing each section of water line, remove all debris and all construction materials from the work site. Then grade and smooth over the surface of both sides of the line. Leave the entire area clean and in a condition satisfactory to the **District**.
- G. No additional payment will be made for pressure testing, taps required for testing, leakage, testing, flushing, bacteriological testing, and water for testing, material, labor and equipment to perform testing.

H. For development related construction, the **District** will not grant final water line acceptance until all other utilities have been completed on the project site.

END OF SECTION

SECTION 3.02

WATER VALVES, HYDRANTS, AND APPURTENANCES

PART 1 – GENERAL

1.01 SECTION INCLUDES

- A. Installation of fire hydrants, valves, and related accessories as specified below.
- B. Refer to other sections for work related to that specified under this heading.

PART 2 - PRODUCTS

2.01 GATE VALVES 4” – 18”

- A. Valves on water lines 2 inches and larger shall be of the resilient seat, non-rising stem type designed to work equally well with pressure on either side of the gate. All gate valves shall be in accordance with or exceed AWWA C515. Working pressure shall be 200 psi. Tapping valves shall also meet the requirements as specified herein. 2-inch gate valves are not permitted.
- B. Valves shall be supplied with O-ring seal stuffing boxes and shall open to the left.
- C. The valve body, bonnet and O-ring plate shall be ductile iron and fully coated with a fusion bonded epoxy coating complying with AWWA C550 and be NSF 61 certified.
- D. Waterways shall be smooth, unobstructed and free of all pockets, cavities and depressions in the set area. Valves 4-inch and larger shall accept a full-size tapping cutter. Each valve shall have maker's name, pressure rating, and year in which it was manufactured cast in the body. Prior to shipment from the factory, each valve shall be tested by hydrostatic pressure equal to the requirements of AWWA C515.
- E. All valves shall open left (counterclockwise) with non-rising stems and shall be provided with a two-inch square operating nut. Valve nut extensions with set screws shall be installed to limit the depth from finish grade to the nut to 30 inches. Valves 4-inches through 12-inches shall be suitable for installation in a vertical position in a buried pipeline.
- F. Valves for buried service shall be equipped with mechanical joint ends and 2-inch square nut for operation. Valves for air release, meter pits, etc. shall be flanged and equipped with handwheels unless otherwise noted.
- G. Valves 16-inch and larger shall be horizontal mounted with bevel gearing.

- H. Valves shall be shipped in a completely closed position with protective end caps.
Valves shall be M&H, Mueller, U.S. Pipe, or approved equal.
- J. Gate valves 16-inch and larger shall have 2 plugs.
- K. Post indicators for by-pass line valves to be factory coated blue in color. Post indicators shall be Kennedy brand or approved equal.
- L. All gate valves shall be connected to adjacent fittings by means of a in-line restraint device. See Section 3.01, Paragraphs 2.02 and 2.03 for restraint devices to be used with valves.

2.02 VALVE BOX CASTINGS AND VALVE BOXES

- A. All valve box castings shall be made accurately to the required dimensions, and shall be sound, smooth, clean, and free from blisters and other defects. Defective castings which have been plugged or otherwise treated to remedy defects shall be rejected. Contact surfaces of frames and covers shall be machined so that the covers rest securely in the frames with no rocking and with the cover in contact with the frames for the entire perimeter of the contact surface. All castings shall be thoroughly cleaned subsequent to machining and before rusting begins. Valve box castings shall be No. 8006 as manufactured by John Bouchard & Sons or approved equal. Cover of valve box shall be marked "WATER".
- B. Valve boxes shall be reinforced concrete with dimensions as shown on the drawings. Each valve box shall be supported by four (4) concrete footing blocks.

2.03 BALL VALVES 2" and less

- A. Ball valves shall be two-piece, bronze body ASTM B584; threaded ends; Blowout-proof stem; PTFE seats packing; stainless steel trim; zinc-plated, plastic covered handle; pressure Ratings: 600 psig, Non-Shock.

2.04 TAPPING VALVES AND TAPPING SLEEVES

- A. Tapping valves shall meet all the requirements of 2.01 above.
- B. Tapping Sleeves in non-traffic areas
 - i. Fabricated steel tapping sleeves shall be as manufactured by Romac Industries, Series FTS420 or JCM 412 meeting requirements of AWWA C223.
 - ii. Pressure rating of 175 psi working pressure and test pressure of 1.25 times working pressure with AWWA C207 Class D flanges, ANSI Class 150 drilling. For 10" and larger branches, Class E flanges shall be furnished.

- iii. Flange: AWWA Class D or E flange, ANSI Class 150 drilling, proper recessing for tapping valves.
 - iv. Body and Outlet Nozzle: Carbon steel, A-36 or equal.
 - v. Outlet Gasket: NBR per ASTM D2000, compounded for water service use.
 - vi. Coating: Fusion epoxy 8-12 mil lined and coated in accordance with AWWA C213.
 - vii. Test Plug: 3/4 –inch NPT type 304 stainless steel plug.
 - viii. Bolts & Nuts: High strength low alloy steel bolts and nuts meeting AWWA C111.
- C. Tapping Sleeves in traffic areas must be epoxy coated mechanical joint as approved by the **District** and the District Engineer.

2.05 FIRE HYDRANTS

- A. Fire hydrants shall comply in all respects with AWWA C-502 and shall be of the compression type, with the main valve opening against the pressure and closing with the pressure.
- B. Operating nut shall be provided with convenient means to afford lubrication to ensure ease of operation and the prevention of wear and corrosion.
- C. Inlet connection shall be six-inch (6”) fusion bonded epoxy coated mechanical joint and fitted with strapping lugs. Main hydrant valve shall be compression type, opening against the pressure and closing with the pressure, with a 5-1/4” valve opening. Traffic feature must be designed for easy 360⁰ rotation of nozzle during construction. Two 2-1/2-inch hose nozzles and one 4-1/2-inch pumper nozzle shall be included. Hose and pumper nozzles shall be threaded and screwed into the nozzle section and then mechanically locked to prevent turning. Caps shall be chained to the hydrant body with non-kink chains. Threads on hose and steamer nozzles and size/shape of operating nut and cap nuts shall conform to National Standard, unless otherwise specified by **District**.
- D. Hydrants shall be dry barrel type and hydrant shoe shall have two positive acting non-corrosive drain valves that shall drain the hydrant completely by opening when the main valve is closed and close tightly in accordance with AWWA C-502 requirements when main valve is open.
- E. The operating nut shall be made of bronze with self-lubricating design. The operating thread shall be sealed from water at all times when the valve is either in the opened or closed position. The operating rod shall be bronze sheathed where it passes through the double “O” ring seal in the bonnet.
- F. The hydrant main valve seat shall be constructed of EPDM rubber and be supported by a one-piece bronze top plate/drain valve mechanism. Drain valve shall have replaceable rubber facings. The bottom stem threads of the main valve

rod shall be fitted with an epoxy coated, cast iron bottom plate, sealing lower rod threads from the water. All below grade bolting shall be 304 stainless steel.

- G. The hydrant shall open by being turned to the left and be so marked on the bonnet in cast letters with an arrow. Hydrant nut shall be pentagonal in shape.
- H. Hydrant shoes shall have an interior and exterior thermosetting epoxy coating of 5 to 6 mils meeting AWWA C550. Exterior of hydrant nozzle section (above ground portions of hydrant) shall be a brilliant yellow enamel finish with the bonnet primed to accept field applied paint colors. The Bonnet color shall be in accordance with NFPA 291 and shall be determined by the **District** and provided to the Contractor for final field painting.
- I. Unless otherwise noted on the plans or required by field conditions, bury shall be 36 inches, with the depth being measured from grade line to top of trench or connecting pipe when outside roadway and 42 inches when water line is located inside roadway. No additional payments will be made for hydrant extensions or hydrants requiring additional bury depth due to field conditions.
- J. Hydrants shall be M&H Style 129S, or Mueller Centurion. No other brand hydrants are permitted.
- K. Bonnets of all newly installed fire hydrants shall include the appropriate flow status color based on the **District** instructions. Hydrants are to have the bonnets color coded in accordance with NFPA 291. Pant shall be factory applied and shall be Tnemec Series 2H Hi-Build Tnene-Gloss or Sherwin-Williams Series B54-Z Pro Industrial Enamel HS Enamel Alkyd Gloss. Colors as as follows:

Flow Rate	Bonnet Color	Tnemec Color Code	Sherwin William Color Code
1500 & greater GPM	Blue	28BL	SW4079
1000-1499 GPM	Green	09SF	SW4083
500-999 GPM-	Orange	04SF	SW4085
499 and less GPM	Red	20RD	SW4081

2.06 AUTOMATIC AIR RELEASE VALVES

- A. Designed to automatically release small pockets of air to atmosphere as they accumulate along a pipeline.
- B. Working Pressure – 250 psi
Test Pressure – 375 psi
- C. Reinforced nylon/Stainless steel base and reinforced nylon/body; NBR 70 o-ring; polypropylene discharge outlet; stainless steel screws; EPDM rolling seal.

- D. Valve shall be A.R.I. S-050 Automatic Air Release Valve or approved equal.
- E. A ductile iron mechanical joint tapped tee to be utilized for air release valve installation. Tee size to match that of main water line and tap size to be 2". Tapped tee shall be Sigma DTTX or approved equal.
- F. A 2-inch ball valve with brass nipples shall be provided to isolate the ARV assembly from the water line.

2.07 BLOW-OFF ASSEMBLIES

- A. Blow-off assemblies shall be complete assembly and as set forth in the Standard Details.

2.08 HYDRANT/SWIVEL TEE AND ANCHOR COUPLING

- A. Hydrant tees and anchor couplings shall be produced in accordance with ANSI/AWWA C-153/A21.53. The fittings shall be ductile iron and rated for a working pressure of 350 psi.
- B. All branch lines for fire hydrants shall include a hydrant tee which shall be directly connected to the hydrant gate valve. In areas where the water main and related appurtenances are located outside the roadway, an anchor coupling (6-inch diameter x 24 inch length) shall be installed between the hydrant gate valve and the hydrant shoe. Utilization of the hydrant tee and anchor coupling provides a fully restrained hydrant connection.
- C. Hydrant tees and hydrant anchor couplings shall be manufactured by American, U.S. Pipe Company, or approved equal.

PART 3 - EXECUTION

3.01 SETTING VALVES AND FITTINGS

- A. General: Set valves, fittings, plugs, and caps and joint to pipe in the manner specified for cleaning, laying, and jointing pipe. Connect system valves to fittings utilizing a bolt-thru mechanical joint restraint device.
- B. Location of Valves: Valves in water mains shall, where possible, be located outside paved areas unless otherwise shown on the drawings.
- C. Restrain valves to adjacent tees and bends with appropriate restraint devices as noted in Paragraph 2.01.L above.
- D. Valve Boxes: Provide a valve box for every valve. The valve box shall not transmit shock or stress to the valve and shall be centered and plumb over the wrench nut of the valve, with the box cover flush with the surface of the finished

pavement or such other level as may be directed by the Engineer. Where the valve operating nut is deeper than 60 inches, a 1.25-inch square tubular operating extension stem shall be provided with set screw to bring the operating nut within 30 inches of the surface. A plate with opening shall be provided in the valve box to maintain the centering of the valve extension shaft. Final grade adjustment of valve boxes shall be made with cut-to-fit precast sections. All public water valve boxes are to be painted blue. All private water valve boxes are to be painted white or silver.

- E. Where a main-line and branch line valve assembly is located (i.e., 3-way valve assembly), the horizontal gate valves, 16-inch and larger, shall be installed with their operating nuts facing away from the branch line so as to prevent crowding of valve boxes.
- F. Tapping Sleeves & Tapping Valves:
1. The Contractor shall make his own arrangements for use of a tapping machine. The **District** does not make taps.
 2. The tapping equipment shall be disinfected with a sodium hypochlorite spray allocation prior to being used for tapping of an existing public water line.
 3. The Contractor shall prepare the trench with an opening of sufficient size to accommodate the tapping machine prior to the start of the tap. Suggested minimum working length is 7 feet.
 4. It shall be the responsibility of the Contractor to measure outside diameters of existing pipes before offering tapping sleeves, or other fittings intended connections to existing mains.
 5. Pipe shall be cleaned of all dirt and debris where tapping saddle is to be located. Tapping saddle shall be located in direction of the new line. Do not rotate the tapping saddle on the existing pipe as it may damage the liner. Tighten and torque all tapping saddle bolts in accordance with the manufacturer's recommendations. After initial application of the saddle and tightening of the bolts, wait a minimum of 24 hours and then re-tighten the bolts and recheck the torque. **District** personnel shall be present to witness torquing of tapping sleeve bolts. Checking bolt tightness without a torque wrench will result in tapping sleeve being failed and unready for tapping. Prior to tapping, the tapping saddle and tapping valve assembly shall be hydrostatically pressure tested at 200 psi for a minimum of 15 minutes to ensure no leakage occurs. Verify operating pressure of line to be tapped with District personnel. Some lines within the system operate in excess of 150 psi. **No air testing of tapping tees will be allowed.**
- G. Air release valves shall be installed in meter boxes as shown on the drawings and shall include a ductile iron mechanical joint tapped tee with bronze nipples and a ball-type isolation valve. Tapped tee shall be set straight and plumb with the air valve oriented at dead top center of the pipe. Refer to Section 3.01. Paragraph 3.07 for more information regarding placement of Air release valves.

- H. All mechanical joint valves shall be installed with restraint devices.

3.02 SETTING HYDRANTS

- A. Location: Locate hydrants as shown on the drawings or as directed by the Engineer and in a manner that will provide complete accessibility and also minimize the possibility of damage from vehicles or injury to pedestrians.
- B. Position: All hydrants shall stand plumb. Set hydrants to the established grade, with nozzles at least 18 inches above the ground, as shown on the drawings or as directed by the Engineer. Pumper nozzle shall face the street. If hydrant is required to adjust height to 18 inches, the contractor shall supply this adjustment at additional payment.
- C. Connection to Main for Fire Hydrant: Connect each fire hydrant to the main with a hydrant/swivel tee, 6-inch gate valve, and 6-inch diameter x 24-inch long anchor coupling.
- D. The hydrant shall be set on footer blocks. Do not cover the drain ports with concrete which might hinder ability of the hydrant to self-drain.
- G. Installed fire hydrants shall receive final bonnet color coding as directed by the District or District Engineer. Repair any damage to the factory coated paint system.
- H. Private fire hydrants inside developments and behind the fire meter shall be painted white or silver.

END OF SECTION

SECTION 3.03

WATER SERVICE ASSEMBLIES

PART 1 - GENERAL

1.01 SECTION INCLUDES

- A. Service assembly requirements for ¾- and 1 - inch service assemblies and service re-connections including residential gang box meter assemblies.

PART 2 - PRODUCTS

2.01 MATERIALS

- A. **Fittings** - All water service materials provided and installed shall be in compliance with the minimum requirements of the “Reduction of Lead in Drinking Water Act”. Line setters to consist of 180° ball type, cut-off, angle type dual check valve assembly; compression fitting on the inlet end and double purpose fitting on the outlet end; and can be no more than a 3.5 inch rise. Line setter shall be A.Y. McDonald NL Meter Setter Model 770-2-WDQD33 (¾” Meter), McDonald NL Meter Setter Model 770-4-WDQD44 (1” Meter) or approved equal. For gang meter boxes, a Ford M111-574 or 674 or 774 or 874-NL 2-inch manifold shall be provided (product number depends on number of meters in box).
- B. **Meter Box (Single Meter)** - Meter Boxes shall be DFW Plastics DF@1324C-18-1 with DFW Plastics Lid DFW1324C-1-Lid , 18 inches deep.
- C. **Meter Box (Gang Meters)** – Meter boxes shall be reinforced precast concrete box measuring 30”x42” minimum interior dimensions for gang meter assemblies up to four meters and 30” x 72” for gang meter assemblies up to eight meters. The lid for a gang meter box shall be a Halliday SIR aluminum single-leaf hatch, appropriately sized for the meter box.
- D. **Water Meters** – Meters shall be furnished through the **District**, unless otherwise noted, after payment for the meters has been received from the developer or contractor.
- E. **Corporation Stops** – Corporation stops shall be ¾-inch. Stops shall be key corporation type stops with AWWA/CC taper thread inlet and quick joint outlet with stainless steel gripper axial restraint. Stops shall be A.Y. McDonald (74701-NL)style or approved equal and shall be in compliance with the minimum requirements of the “Reduction of Lead in Drinking Water Act”.

- F. **Service Saddles and Service Connections** – Connections for ¾-inch and 1-inch services shall be direct tapped with the corporation stop onto the ductile iron pipe. Connections for 2-inch services shall utilize a line size by 2-inch tapped tee.
- G. **Service Saddles on PVC Pipe** – Service saddles shall be Smith-Blair Model 315 single stainless steel strap design or approved equal.
- H. **Service Pipe** – Service pipe shall PEXa Municipex by Rehau®. Service pipe under streets, roadways, and sidewalks shall be installed in 2-inch diameter DR 9 HDPE casing pipe (blue in color) for ¾-inch or 1-inch service lines. Depth of pipe is to be no less than eighteen inches (18”) and no more than twenty-four inches (24”) for short-side services. Casing pipe for long-side services shall be installed to be a minimum of thirty-six inches (36”) depth or as noted on plans. Detection tape (2 inch wide, blue in color) shall be placed 12 inches above all service lines. Each end of the service lines to have stainless steel inserts.
 - 1. **Service Piping**
 - a. All pipe shall be crosslinked polyethylene manufactured using the high-pressure peroxide method of crosslinking (known as PEXa). Pipe shall conform and be third-party certified to AWWA C904, ASTM F876, CSA B137.5, NSF/ANSI 14 and NSF/ANSI 61.
 - b. Pipe shall be rated for continuous operation of 100 psi gauge pressure at 180°F temperature (690 kPa @ 82°C), and 160 psi gauge pressure at 73.4°F temperature (1105 kPa @ 23°C) as defined in AWWA C904.
 - c. Pipe shall be rated for continuous operation at 200 psi gauge pressure at 73°F temperature (1378 kPa @ 23°C) when evaluated using a 0.63 design factor (see item 20 for details).
 - d. Pipe shall be listed by PPI to standard TR-3 as Standard Grade,
 - e. Pipe to be tested for resistance to hot chlorinated water in accordance with ASTM F2023. Pipe to have a minimum Class 3 chlorine resistance rating when evaluated to F876 and tested in accordance to F2023.
 - f. PEXa pipe shall be listed with a material designation code of “3306” per the ASTM F876 standard and PPI TR-3.
 - g. Pipe to have a co-extruded UV Shield made from UV-resistant polyethylene, color blue. Pipe to have minimum recommended UV exposure time of 12 months when tested in accordance with ASTM F2657 and evaluated in accordance with ASTM F876.
 - h. Pipe shall be manufactured in a facility whose quality management system is certified according to ISO 9001.
 - i. Bend Radius: The minimum bend radius for cold bending of PEXa pipe shall not less than five (5) times the outside diameter.
 - j. No joints will be allowed in service line piping.
- I. **Pipe Stands for Gang Meter Boxes** – Provide two (2), one-inch diameter pipe stands, B-Line 3088T with 3093 Adjustable stand and pipe yoke for 2” pipe per gang box. Stands, adjusters and yokes shall be electro-galvanized.

PART 3 – EXECUTION

3.01 PREPARATION

- A. The service line shall have a minimum of 18 inches cover. After the pipe line is installed and the line setter installed, turn water on service pipe, blowing any accumulated trash out of the pipe.
- B. Backfill shall be carefully placed around service line and hand-tamped into place. Service line backfill shall be free of rock, roots, debris, trash or other deleterious materials. Exercise caution while backfilling so as to not kink or otherwise damage the service line.

3.02 INSTALLATION

- A. All service lines to be installed under paved county, City or State roads and sidewalks will be bored where applicable. A 2-inch DR 9 HDPE casing pipe shall be included with all bored service lines and be extended 1 foot from the water main to within 6 inches of the meter. No joints will be allowed in the casing pipe.
- B. The service line shall not be taut from stop to cock. Leave some slack in the service line as it is installed.
- C. Corporation cocks shall be directly tapped onto new ductile iron pipe. No tapping saddle is required unless the tap is on a PVC water main. Corporation cocks placed on PVC water mains shall include a service saddle.
- D. New meter boxes shall be set flush and level with final ground surface elevation. Box shall be installed atop 2 inches of crushed stone beneath the boxes.
- E. Adjust gang box pipe stands to support the meter manifold.
- F. The **District** will install new meters in each new residential service assembly, unless otherwise notified.
- G. All service line final connections between new service line and existing meters or new service line and new meters shall be water tight without evidence of leakage. New service lines shall be renewed completely from the water main to the existing meter. If leaks occur on service lines, replace all service line with new service line.
- H. After meters and gang boxes have been set, Contractor shall mark, flag and protect all new meter boxes and assemblies while building construction is underway. Meter boxes damaged by builders' forces or equipment will be repaired by the **District** and back-charged to the **Developer** for the **repairs**.

Continued damage to meter assemblies during building construction may result in the cut-off of all water meters until such time that adequate protection is provided to the meters to avoid damage.

- I. Once service lines and meter boxes are installed, restore all surrounding disturbed areas to pre-existing conditions. Seed and mulch all disturbed areas.

END OF SECTION

SECTION 4.01

CONCRETE FOR UTILITY LINES

PART 1 - GENERAL

1.01 SECTION INCLUDES

- A. Furnishing and installing concrete blocking, cradles, anchors, caps, pipe protection, and/or encasement at the locations directed by the Engineer or District.

PART 2 - PRODUCTS

2.01 MATERIALS

- A. Concrete work shall conform to ACI 301, latest revision, as modified by the supplemental requirements below:
 - 1. Strength: The strength of concrete shall be 4,000 psi unless otherwise shown on the drawings.
 - 2. Durability: All concrete exposed to weather shall be air entrained.
 - 3. Slump: Concrete shall be proportional and produced to have a slump of three (3) inches with a one (1) inch tolerance.
 - 4. Admixtures: Air entrainment, mandatory for concrete exposed to weather, may be used. A water reducing admixture (retarding, normal, or accelerating, depending on placing temperature), may be used if approved by the **District**.
 - 5. Reinforcing Steel: Yield strength of reinforcing steel shall be 60,000 psi.
- B. PRE-MIXED (BAGGED) CONCRETE
 - 1. Bagged concrete mix shall be approved by the District prior to use.
 - 2. Bagged concrete mix shall be mechanically mixed and water added per the manufacturer's recommendations.
 - 3. Allowable products:
 - a. Sakrete High Strength or Sakrete Fast Setting mixes.
 - b. Quikrete No. 1101 or No. 1004 .

PART 3 – EXECUTION

3.01 INSTALLATION

- A. Perform concrete work in accordance with recommendations of ACI-301.

END OF SECTION

SECTION 5.0

STANDARD CONSTRUCTION DETAILS TABLE OF CONTENTS

5.01W	Trench Detail
5.02W	Typical Concrete Valve Box
5.03W	Typical Fire Hydrant w/Valve Setting
5.04W	Horizontally Installed Gate Valve Setting (valves 14" and larger)
5.05W	Typical Concrete Thrust Blocking
5.06W	Reverse Thrust Block
5.07W	2" Blow-off Assembly
5.08W	¾" or 1" Service Assembly (Short Side)
5.08W-FS1	Residential Fires Sprinkler Meter Detail
5.08W-FS2	Residential Fire Sprinkler System Notes
5.09Wa	¾" or 1" Service Assembly (Long Side) w/sidewalks
5.09Wb	¾" or 1" Service Assembly (Long Side) w/o sidewalks
5.10Wa	3 to 4 Unit Town Home Meter Assembly – Plan
5.10Wb	3 to 4 Unit Town Home Meter Assembly – Section
5.10Wc	5 to 8 Unit Town Home Meter Assembly – Plan
5.10Wd	5 to 8 Unit Town Home Meter Assembly – Section
5.10We	General 3 to 8 Unit Town Home Meter Assembly Notes
5.11W	1.5" and 2" Meter Assembly
5.12W	3" Meter Assembly
5.13Wa	4" - 8" Fire Meter - Plan
5.13Wb	4" - 8" Fire Meter - Section
5.13Wc	3" to 8" Meter Internal Pipe Layout
5.14Wa	10" Fire Meter Assembly – Plan
5.14Wb	10" Fire Meter Assembly – Section
5.14Wc	10" Fire Meter Internal Pipe Layout
5.15W	General Meter Assembly Notes - (1.5" – 10")
5.16W	2" Air Release Assembly
5.17W	Typical Utility Separation
5.18W	Post Indicator Valve
5.19W	Bore and Jack for Highways
5.20W	Standard Casing Spacer and End Seals
5.21W	Creek Crossing
5.22W	Concrete Protection for Utility Lines
5.23W	Pavement Repair
5.24W	Filter Bag for Creek Crossing
5.25W	Temporary Silt Fence
5.26W	Straw Bale Barrier
5.27W	Stone (Rock) Check Dam
5.28W	Temporary Construction Entrance
5.29W	MJ Anchor Couplings

EXISTING PAVEMENT OR
CRUSHED STONE SURFACE
SUB-BASE AND PAVEMENT EQUAL OR
BETTER THAN EXISTING SURFACE
8" CRUSHER RUN OR AS REQ'D.
BY THE HIGHWAY DEPT.

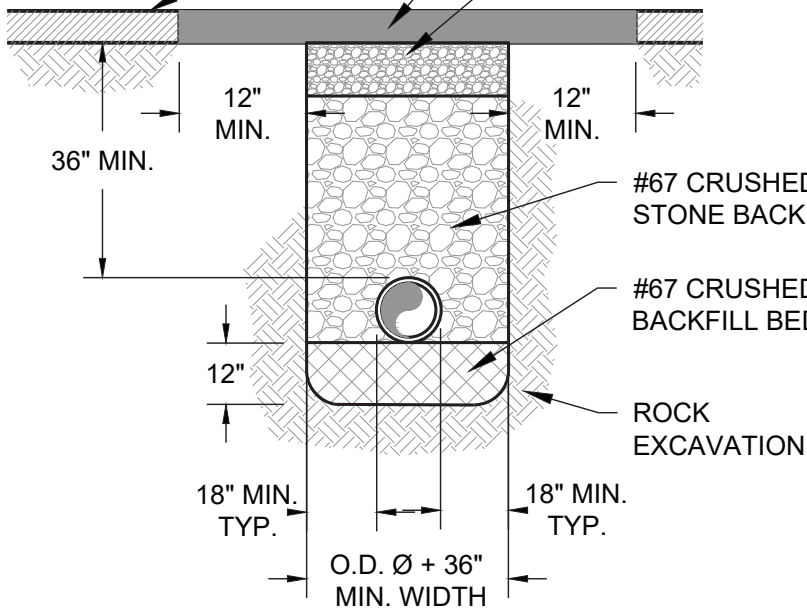

NOTES:

1. 36" MINIMUM COVER AND 60" MAX. COVER FOR ALL WATER LINES UNLESS OTHERWISE SHOWN.
2. FOR TRENCHES DUG IN SHOT ROCK BACKFILL AREAS, #67 CRUSHED STONE BACKFILL TO BE USED FOR BEDDING AND BACKFILL.

**ALL PIPE IN TRAFFIC
PAVED AREAS**

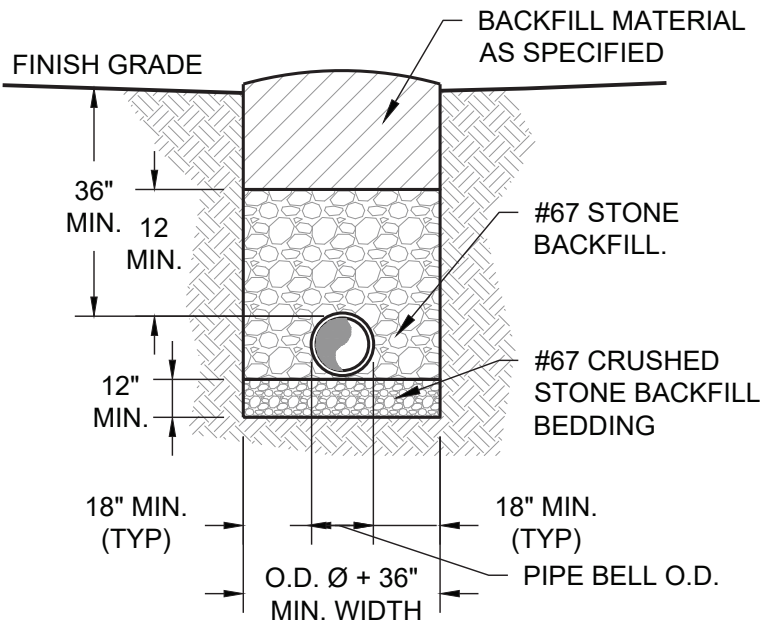

**DUCTILE IRON PIPE
IN ROCK**

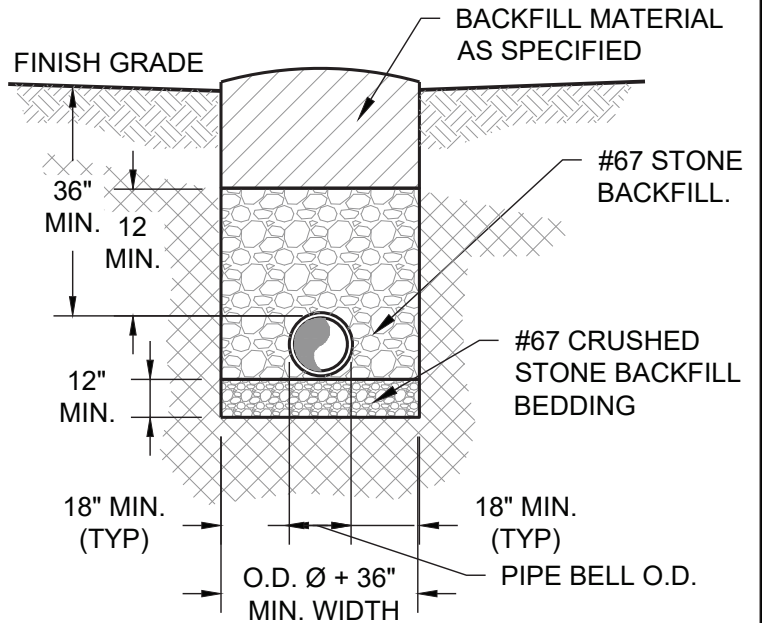

**DUCTILE IRON PIPE
IN EARTH**

TRENCH DETAILS

NOT TO SCALE

FOUR (4) CONCRETE BLOCKS OF THE SIZE AND SHAPE SHOWN ARE TO BE PLACED UNDER EACH VALVE BOX, ONE UNDER EACH CORNER OF BOX.

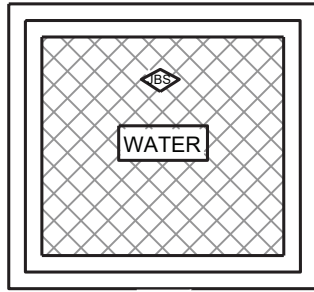
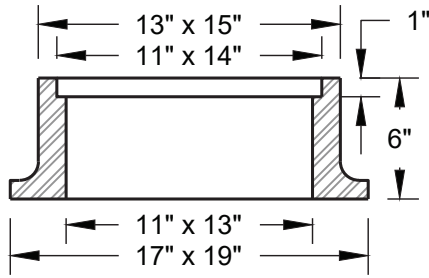

8006

FRAME AND COVER

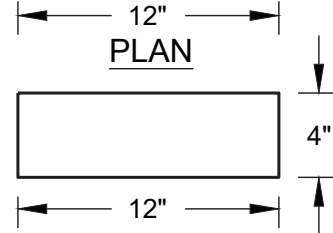
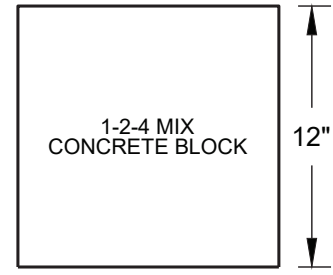
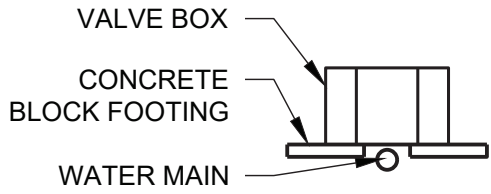
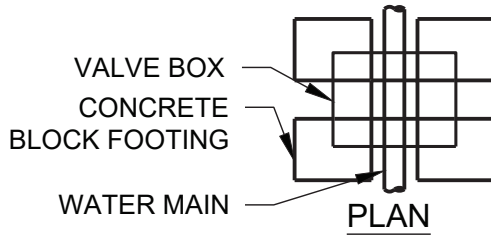

ELEVATION

FOOTINGS

NOTES:

1. VALVE BOX FRAME AND COVER SHALL BE JOHN BOUCHARD AND SONS 8006 FRAME AND COVER, STAMPED "WATER".
2. GATE VALVES 16" AND LARGER SHALL BE HORIZONTALLY MOUNTED WITH BEVEL GEARING.
3. BEFORE INSTALLATION OF VALVE BOXES AND FOOTINGS THE EARTH ON WHICH THE FOOTINGS AND VALVE BOXES ARE TO BE SET SHALL BE BACKFILLED AND THOROUGHLY TAMPED AND COMPACTED.

SETTING

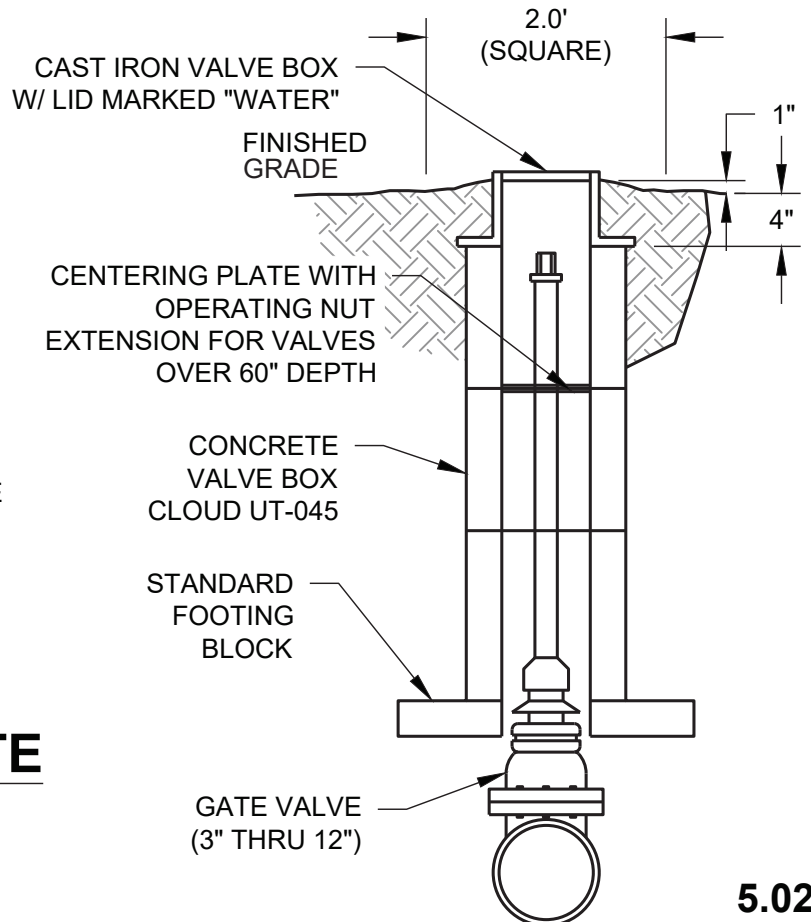

TYPICAL CONCRETE VALVE BOX
NOT TO SCALE

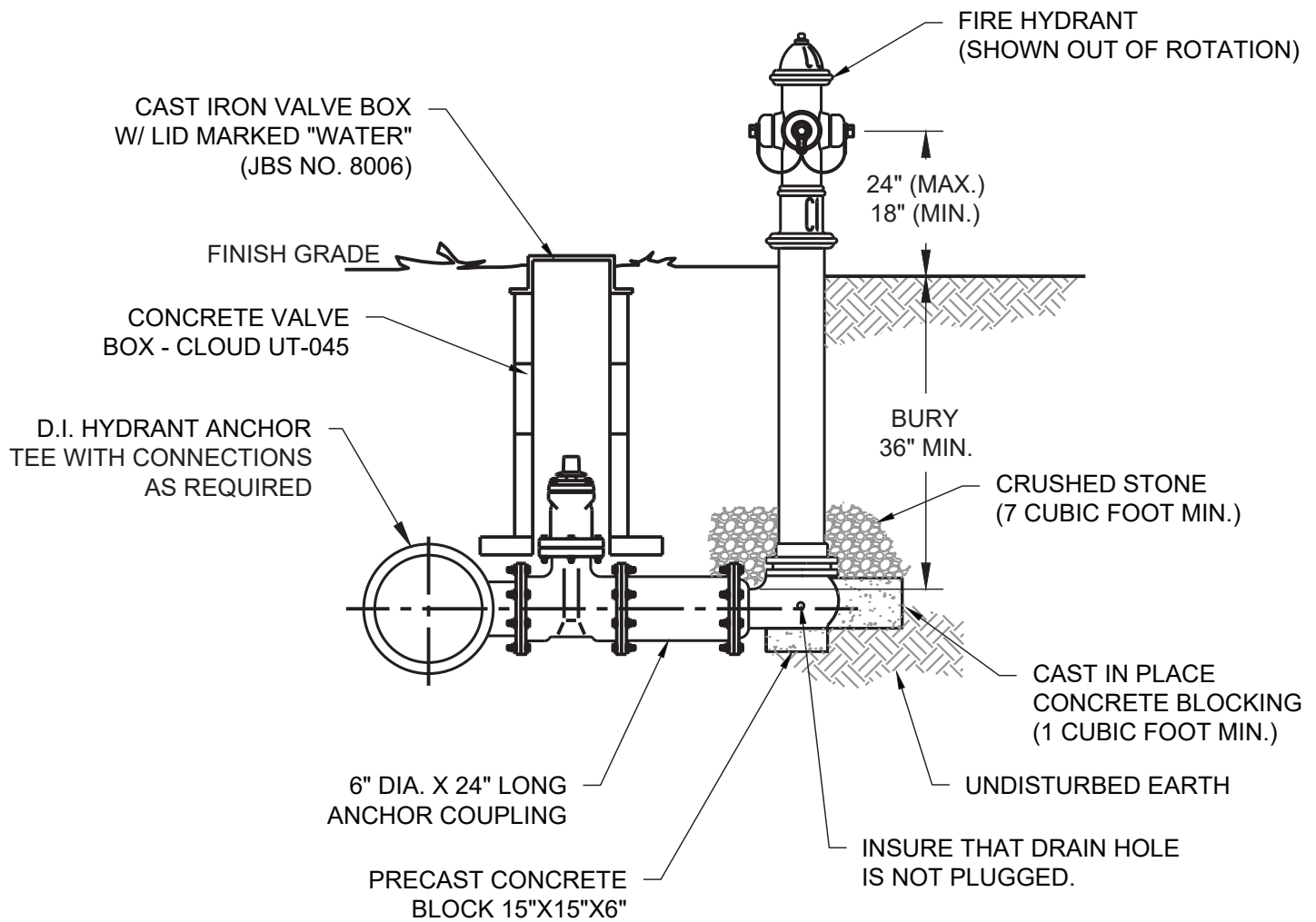

NOTES:

1. THE BURY DEPTH FOR THE HYDRANT AS SHOWN HEREIN IS A MINIMUM DEPTH. HYDRANTS SHALL BE FURNISHED AND INSTALLED WITH A SITE SPECIFIC OR LOCATION SPECIFIC BURY DEPTH.
2. FOR LENGTHS UP TO 5', USE AN ANCHOR COUPLING. FOR LENGTH GREATER THAN 5', USE 6" DIP CL 52 WITH APPROPRIATE RESTRAINT DEVICES.
3. HYDRANT SHALL OPEN BY TURNING OPERATING NUT TO THE LEFT. OPERATING NUT SHALL BE PENTAGONAL IN SHAPE AS CONFORMING TO DISTRICT STANDARDS.
4. FIRE HYDRANT SHALL HAVE A 5-1/4" MAIN VALVE OPENING AND SHALL BE M & H STYLE 129, TRAFFIC MODEL 5378 OR MUELLER CENTURION, PAINTED FACTORY YELLOW.
5. MAXIMUM ALLOWED HYDRANT EXTENSION LENGTH IS 4 FEET AND SHALL BE DONE WITH MINIMUM NUMBER OF EXTENSIONS AS POSSIBLE. IF HYDRANT IS EXTENDED, THE HYDRANT BREAKAWAY COUPLING TO BE MOVED TO THE TOP EXTENSION PIECE.

FIRE HYDRANT W/ VALVE SETTING

NOT TO SCALE

5.03W
02/2026

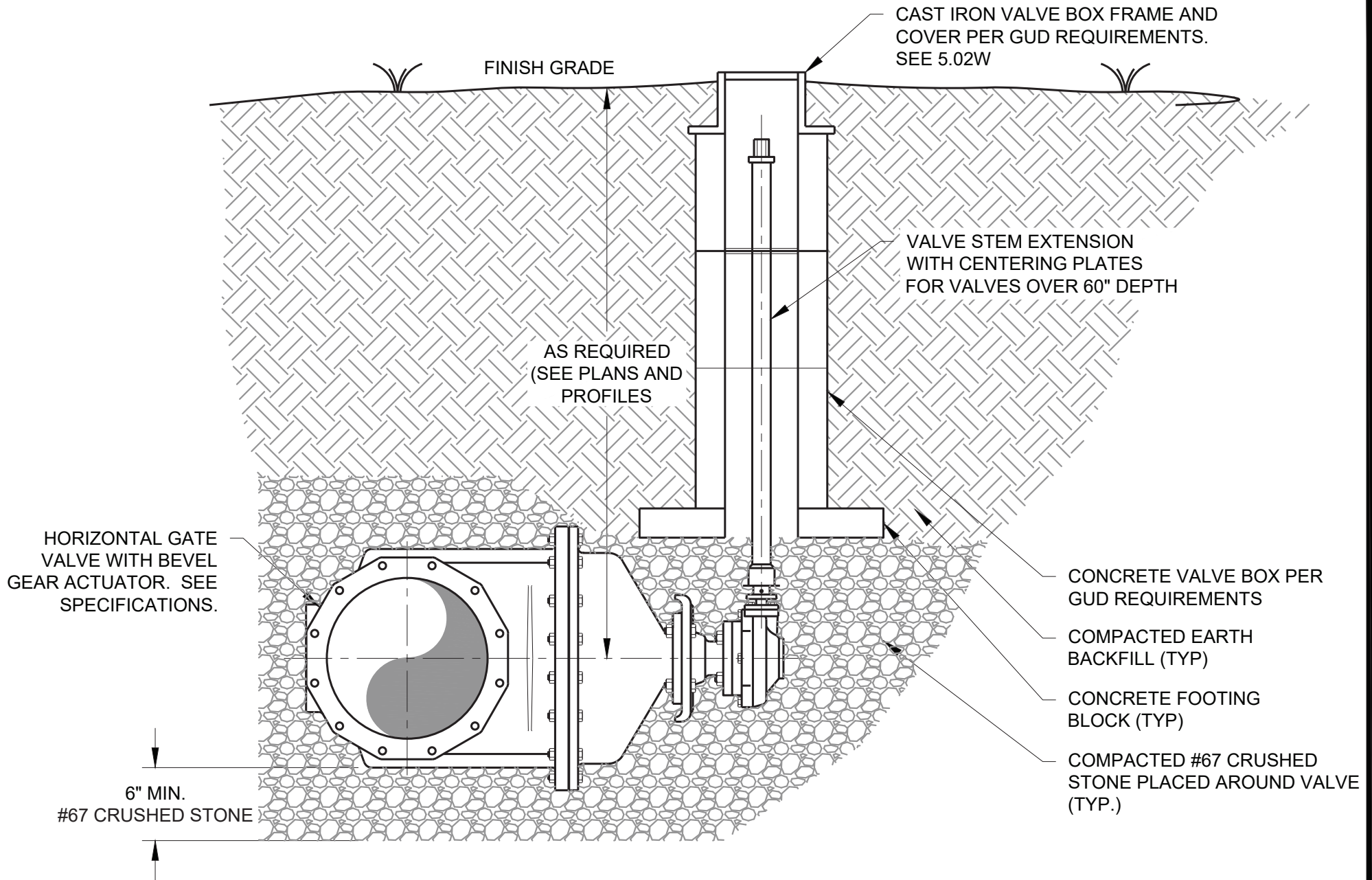

**HORIZONTALLY INSTALLED GATE VALVE SETTING DETAIL
(FOR VALVES 14" AND LARGER)**

NOT TO SCALE

**5.04W
02/2026**

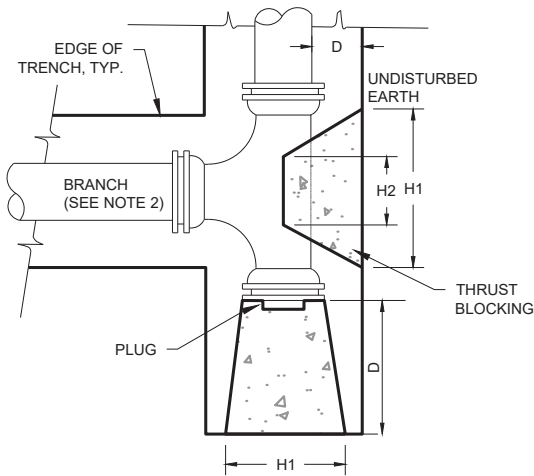

TEES, CROSSES AND PLUGS

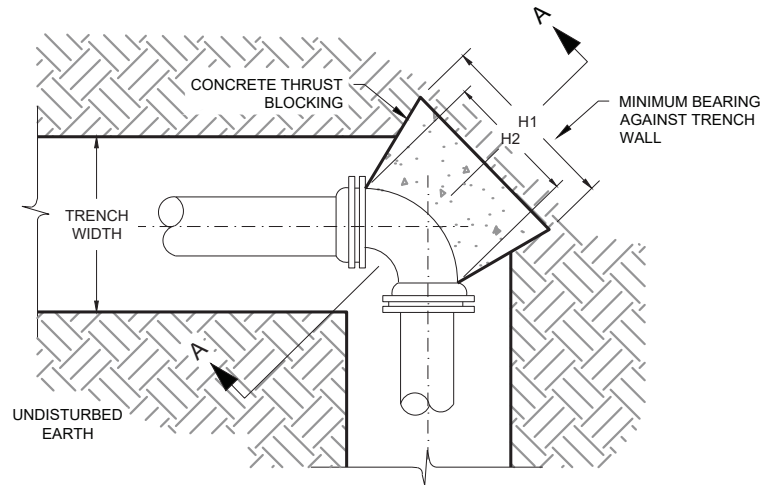

HORIZONTAL BENDS

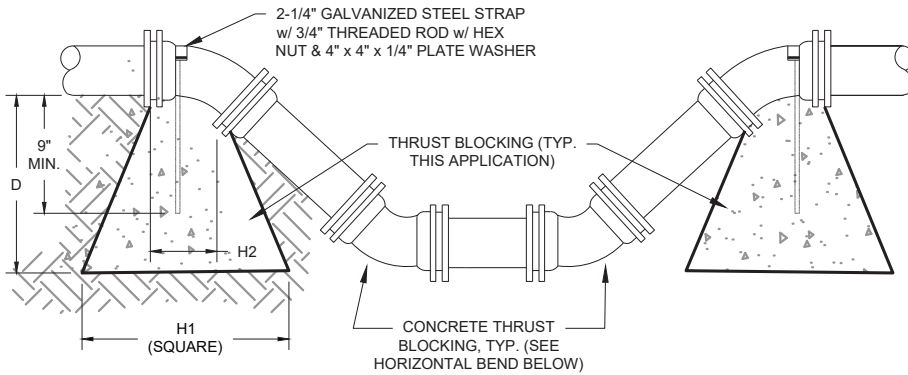

VERTICAL BENDS

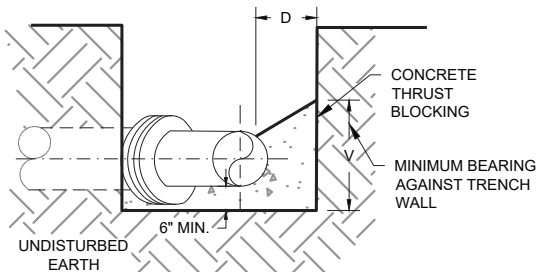

SECTION A-A

TABLE OF DIMENSIONS FOR CONCRETE BLOCKING

TEES, CROSSES & PLUGS					90° BENDS				45° BENDS				22-1/2° BENDS				11-1/4° BENDS				PIPE SIZE				
H1	H2	V	D	C.F.	H1	H2	V	D	CF	H1	H2	V	D	C.F.	H1	H2	V	D	C.F.	H1	H2	V	D	C.F.	2" - 2-1/4"
18"	10"	12"	18"	1.90	18"	10"	12"	18"	1.90	18"	6"	12"	18"	1.50	18"	6"	12"	18"	1.50	18"	6"	12"	18"	1.50	3" - 4"
24"	12"	12"	18"	2.25	24"	12"	12"	18"	2.24	18"	8"	12"	18"	1.60	18"	8"	12"	18"	1.60	18"	8"	12"	18"	1.60	6"
24"	16"	18"	18"	3.50	30"	16"	18"	18"	4.05	24"	10"	16"	18"	3.20	24"	10"	16"	18"	3.20	24"	10"	16"	18"	3.20	8"
36"	18"	18"	18"	5.05	39"	18"	24"	18"	7.30	30"	12"	18"	18"	3.95	24"	12"	18"	18"	3.45	24"	12"	16"	18"	3.40	10"
48"	24"	18"	24"	7.15	54"	32"	24"	18"	10.25	36"	18"	21"	18"	4.60	24"	18"	21"	18"	4.60	24"	18"	21"	18"	4.60	12"
54"	30"	24"	24"	13.40	54"	32"	36"	24"	18.15	42"	18"	24"	24"	9.60	24"	18"	24"	24"	6.60	24"	18"	21"	24"	6.10	14"
60"	32"	30"	24"	17.90	60"	40"	42"	24"	25.00	44"	24"	30"	24"	13.20	30"	24"	24"	24"	9.20	27"	21"	24"	24"	7.90	16"
66"	34"	36"	24"	22.50	69"	48"	48"	24"	29.00	48"	30"	36"	24"	17.00	36"	30"	27"	24"	11.80	27"	21"	27"	24"	9.10	18"
66"	36"	40"	24"	27.50	69"	48"	48"	24"	33.00	48"	30"	36"	24"	17.00	36"	30"	29"	24"	13.00	27"	24"	29"	24"	11.00	20"
	38"		24"			48"		24"			40"		24"			36"		24"			30"	27"		28"	24"
	42"		24"			60"		24"			48"		24"			42"		24"				29"		32"	24"
	58"		24"			96"		24"			72"		24"			72"		24"						36"	

NOTES:

- MECHANICAL RESTRAINT DEVICES ARE REQUIRED FOR ALL M.J. FITTINGS. CONCRETE THRUST BLOCKING MAY ALSO BE REQUIRED AT THE DISCRETION OF THE OWNER.
- DIMENSIONS ARE CONTROLLED BY DIAMETER OF BRANCH MAIN.

TYPICAL CONCRETE THRUST BLOCKING

NOT TO SCALE

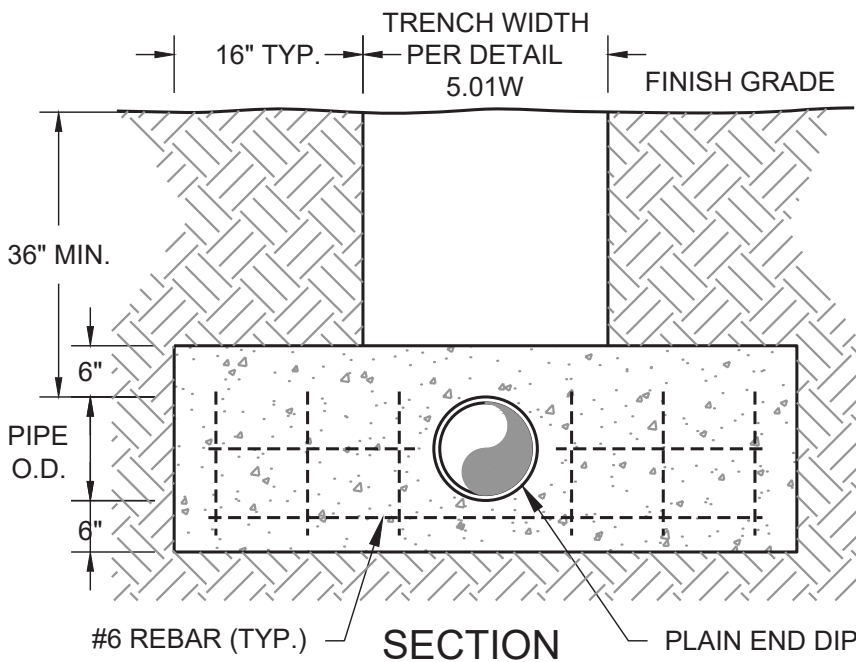
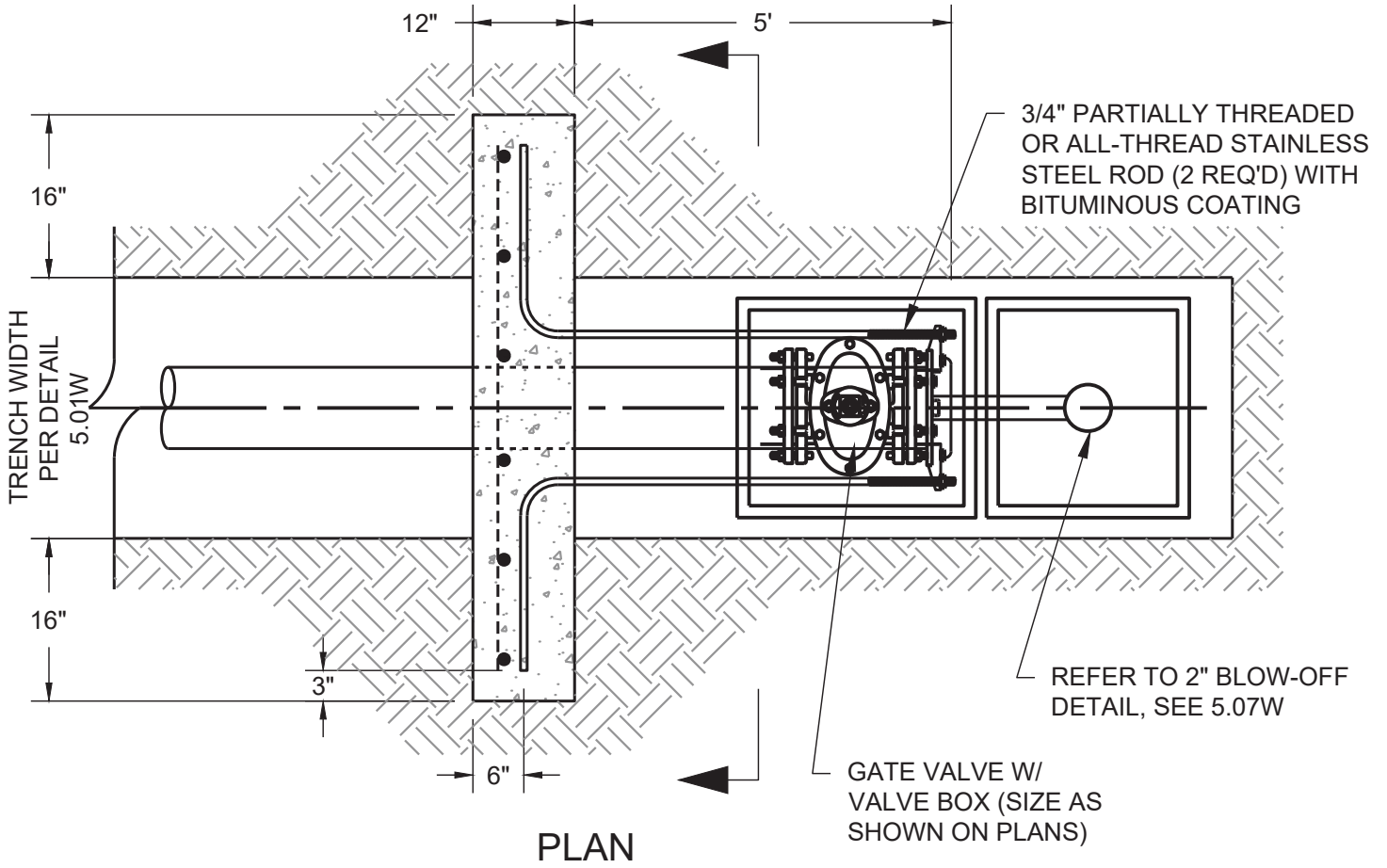

NOTES:

1. ANCHOR BLOCK CONCRETE SHALL BE 4000 PSI.
2. ALL STEEL RODS, BOLTS, TIES, ETC. IN CONTACT WITH SOIL SHALL BE COATED WITH COAL TAR COATING SYSTEM SIMILAR TO TNEMEC HB TNEMECOL OR EQUAL AND BE STAINLESS STEEL.
3. CONCRETE SHALL BE POURED AGAINST UNDISTURBED EARTH.
4. DIMENSIONS ARE BASED ON 2000 P.S.F. SOIL BEARING CAPACITY PRESSURE AND 6000 LB. REINFORCING BAR TENSILE STRENGTH.

REVERSE THRUST BLOCKING

NOT TO SCALE

5.06W
02/2026

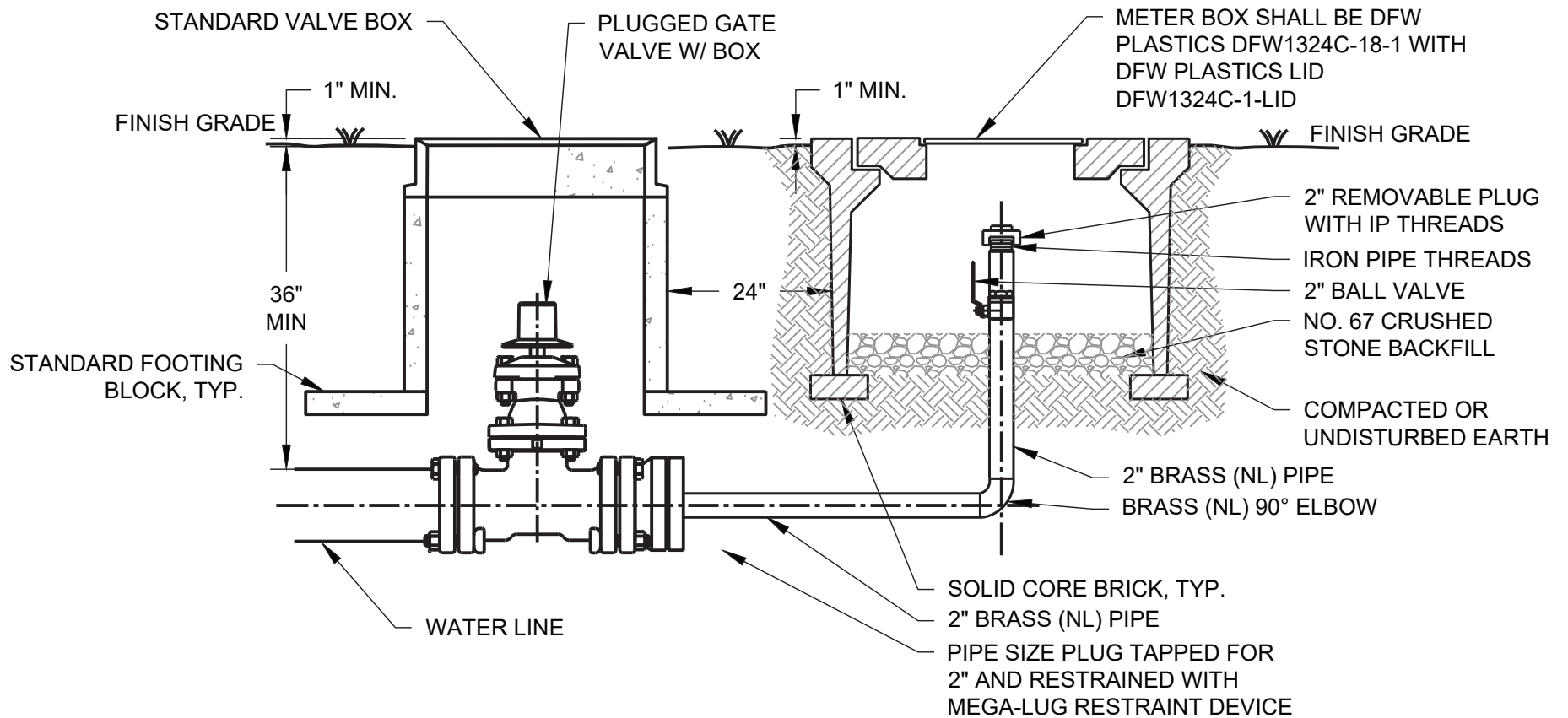

2" BLOW-OFF ASSEMBLY

NOT TO SCALE

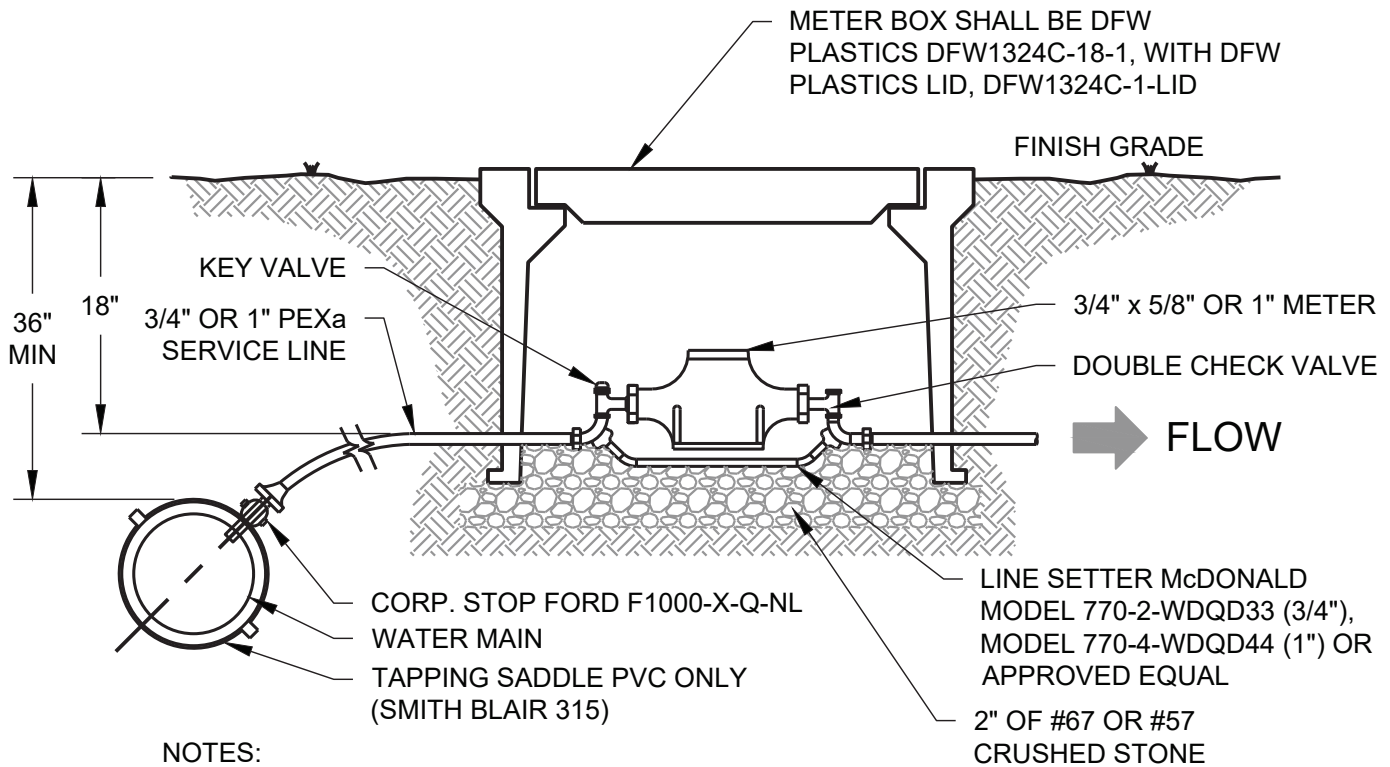

1. FOR TAPS IN PVC PIPE USE TAPPING SADDLE. DIRECT TAP DUCTILE IRON PIPE.
2. SERVICES UNDER EXISTING ROADWAY ARE TO BE BORED AND JACKED. SERVICE LINE UNDER PAVEMENT TO BE INSTALLED INSIDE 2"HDPE (CONTINUOUS) CARRIER PIPE ON 3/4" OR 1" SERVICES.
3. REFER TO STANDARD SPECIFICATIONS FOR TECHNICAL REQUIREMENTS OF EACH ITEM.
4. WATER TAPS ON NEW WATER MAINS TO BE MADE BY CONTRACTOR. WATER TAPS ON EXISTING WATER MAINS WILL BE MADE BY GLADEVILLE UTILITY DISTRICT.
5. EACH END OF PEXa SERVICE LINES TO HAVE STAINLESS STEEL INSERTS.

3/4" OR 1" SERVICE ASSEMBLY (SHORT SIDE)

NOT TO SCALE

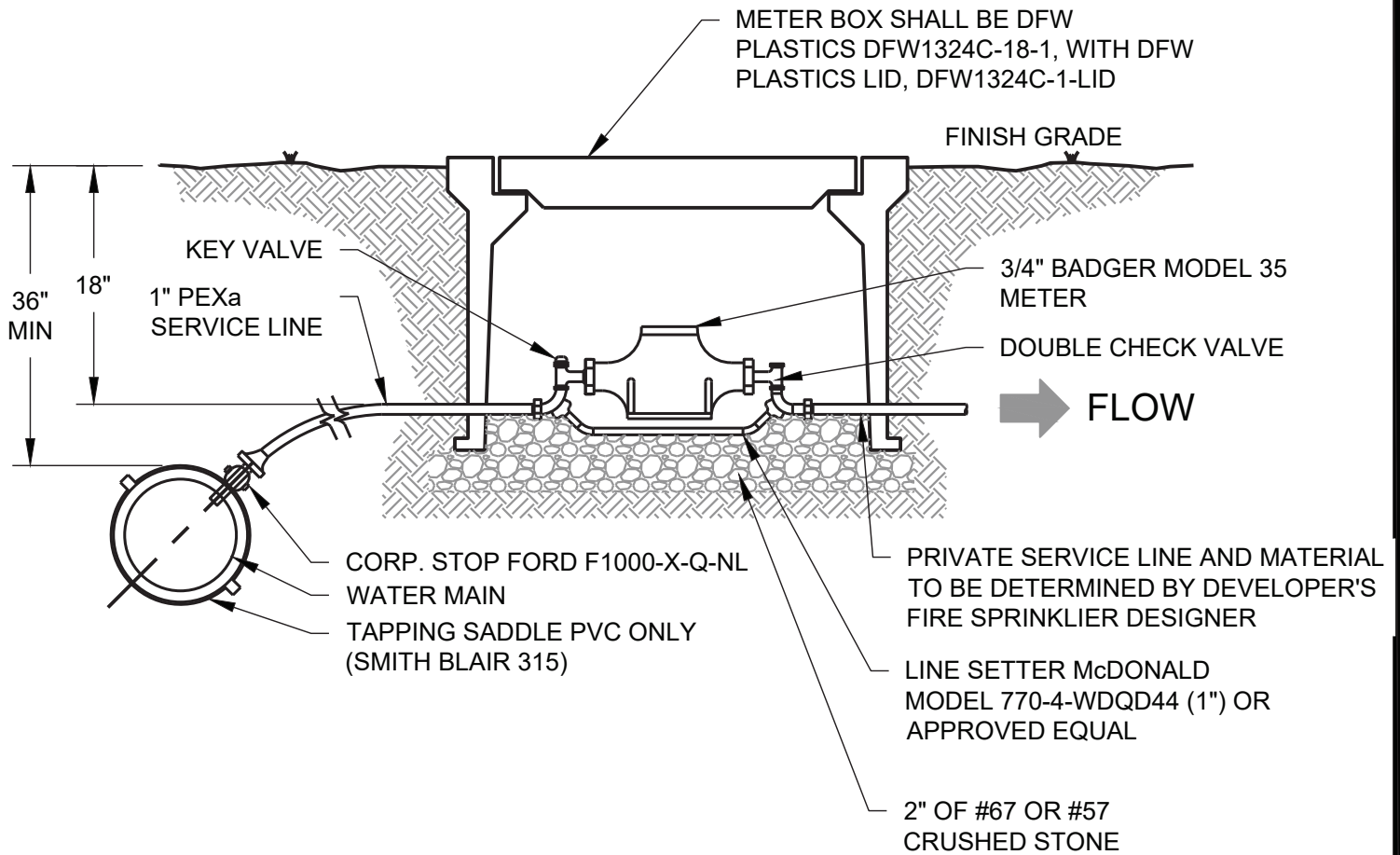

NOTES:

1. FOR TAPS IN PVC PIPE USE TAPPING SADDLE. DIRECT TAP DUCTILE IRON PIPE.
2. SERVICES UNDER EXISTING ROADWAY ARE TO BE BORED AND JACKED. SERVICE LINE UNDER PAVEMENT TO BE INSTALLED INSIDE 2"HDPE (CONTINUOUS) CARRIER PIPE.
3. REFER TO STANDARD SPECIFICATIONS FOR TECHNICAL REQUIREMENTS OF EACH ITEM.
4. WATER TAPS ON NEW WATER MAINS TO BE MADE BY CONTRACTOR. WATER TAPS ON EXISTING WATER MAINS WILL BE MADE BY GLADEVILLE UTILITY DISTRICT.
5. EACH END OF PEXa SERVICE LINES TO HAVE STAINLESS STEEL INSERTS.
6. LINE SETTER TO BE SUPPLIED WITH (2) 3/4" X 1" METER ADAPTER KIT (McDONALD MODEL 710J24).

**REFER TO 5.08W-FS2 FOR RESIDENTIAL FIRE
SPRINKLER REQUIREMENTS**

RESIDENTIAL FIRE SPRINKLER METER DETAIL

NOT TO SCALE

**5.08W-FS1
02/2026**

NOTES:

1. IT WILL BE THE DEVELOPER/HOME BUILDERS RESPONSIBILITY TO DESIGN AND SIZE ALL COMPONENTS ASSOCIATED WITH A RESIDENTIAL FIRE SPRINKLER SYSTEM, INCLUDING METER AND TAP SIZE.
2. THE DEVELOPERS FIRE SPRINKLER ENGINEER SHALL ACKNOWLEDGE IN WRITING TO THE DISTRICT THAT RESIDENTIAL FIRE SERVICE ASSEMBLIES ARE ADEQUATELEY SIZED TO ACCOMMODATE THE FIRE SPRINKLER FLOW AND PRESSURE REQUIREMENTS FOR THE DEVELOPMENT IN ACCORDANCE WITH NFPA 13R OR THE LOCAL FIRE MARSHALL GOVERNING THE DEVELOPMENT.
3. THE DISTRICT **DOES NOT** GUARANTEE ANY FLOWS OR PRESSURE MINIMUMS WITH REGARD TO FIRE HYDRANTS OR SPRINKLER SYSTEMS.
4. THE DISTRICT ASSUMES NO RESPONSIBILITY FOR ENSURING THAT THE INSTALLATION OF RESIDENTIAL FIRE SPRINKLER SYSTEMS COMPLIES WITH ANY CODES, REGULATIONS, OR STANDARDS OTHER THAN THOSE OF THE DISTRICT. IT SHALL BE THE DEVELOPER/HOME BUILDERS RESPONSIBILITY TO COMPLY WITH ALL APPRICABLE RULES AND LAWS.
5. RESIDENTIAL DWELLINGS REQUIRING A RESIDENTIAL FIRE SPRINKLER SYSTEM MUST HAVE A PASSIVE/FLOW-THROUGH SPRINKLER SYSTEM INSTALLED.
6. BEFORE THE DISTRICT WILL INSTALL THE METER FOR THE RESIDENTIAL DWELLING, DOCUMENTATION FROM THE GOVERNING FIR MARSHALL MUST BE PROVIDED TO THE DISTRICT STATING AN INSPECTION WAS MADE VERIFYING THE PASSIVE PURGE/FLOW-THROUGH SPRINKLER SYSTEM WAS APPROPRIATELY INSTALLED.

RESIDENTIAL FIRE SPRINKLER
STSTEM NOTES

NOT TO SCALE

5.08W-FS2
02/2026

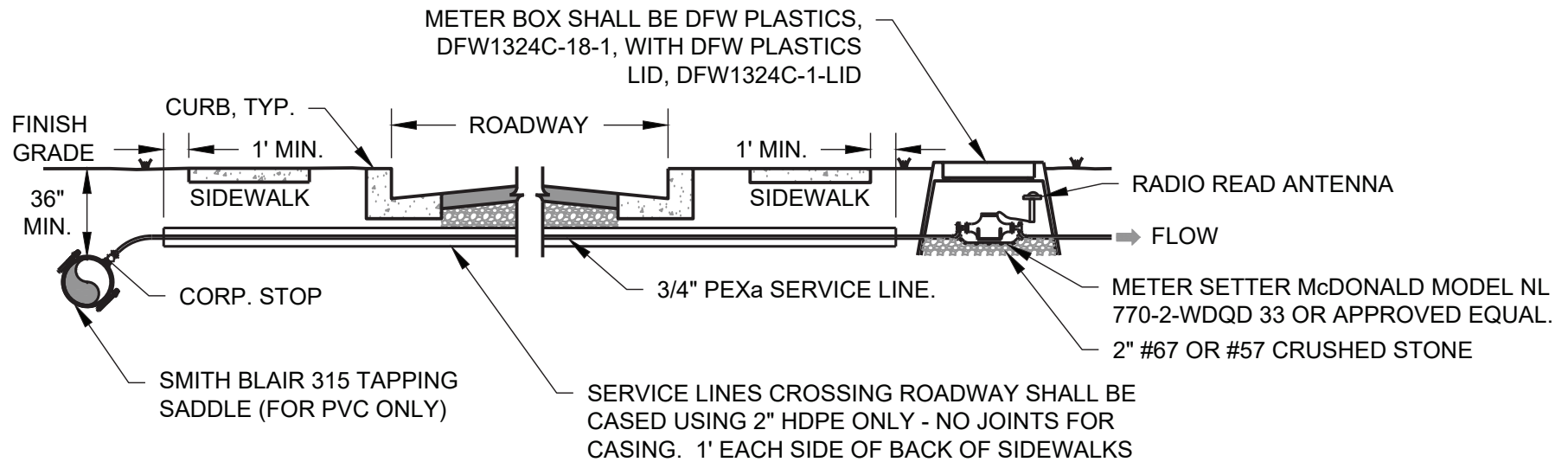

NOTES:

1. WATER MAIN CASING MUST EXTEND FROM TOE OF SLOPE TO TOE OF SLOPE.
2. DITCH CROSSING - CASING MUST BE MINIMUM 24" BELOW BOTTOM OF DITCH.
3. ALL 2" CASING PIPE NEEDS TO BE DUCT TAPED ON THE ENDS.
4. 2" CASING SHOULD RUN FROM 1' OFF WATER MAIN TO 6" OFF METER BOX, BUT UNDER NO CIRCUMSTANCES END UNDER THE ROAD, SIDEWALK OR ANY OTHER SURFACE BARRIER.

3/4" OR 1" SERVICE ASSEMBLY (LONG SIDE) WITH SIDEWALKS

NOT TO SCALE

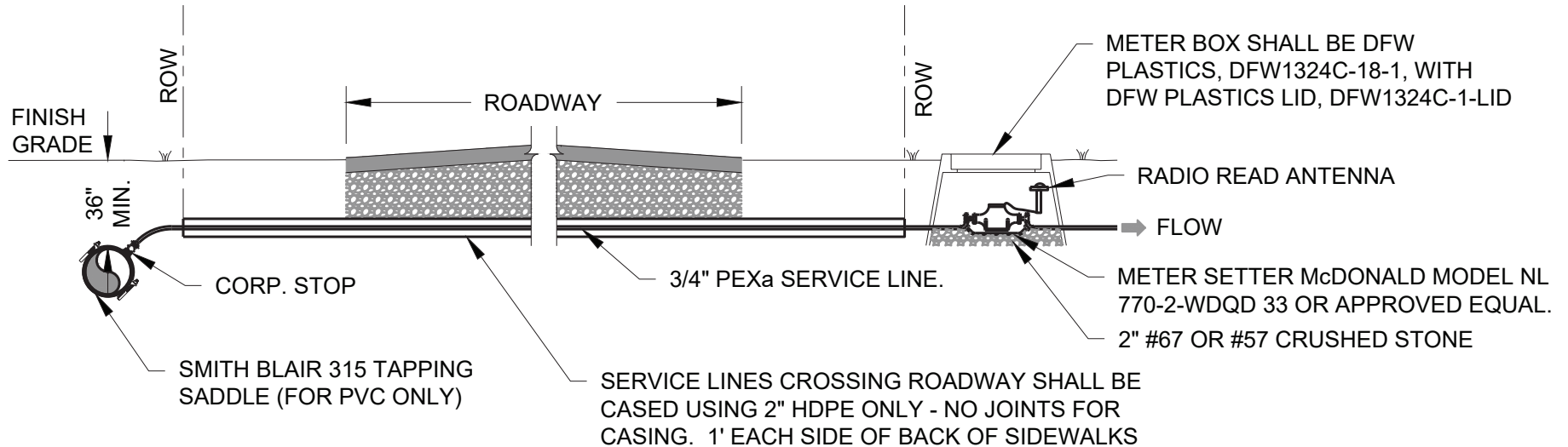

NOTES:

1. WATER MAIN CASING MUST EXTEND FROM ROW TO ROW.
2. DITCH CROSSING - CASING MUST BE MINIMUM 24" BELOW BOTTOM OF DITCH.
3. ALL 2" CASING PIPE NEEDS TO BE DUCT TAPED ON THE ENDS.
4. UNDER NO CIRCUMSTANCES END UNDER THE ROAD, SIDEWALK OR ANY OTHER SURFACE BARRIER.
5. CASING SHALL BE INSTALLED BY DIRECTIONAL BORING AND SHALL BE CONTINUOUS FROM ROW TO ROW WITH AT LEAST 42" COVER WHERE UNDER ROADWAY.

3/4" OR 1" SERVICE ASSEMBLY
(SHORT SIDE) WITHOUT SIDEWALKS

NOT TO SCALE

VAULT REINFORCING

28 DAY, 5000 PSI CONCRETE. #3 GRADE 60 REBAR @ 12"
O.C.E.W. PER ASTM C993 AND C990

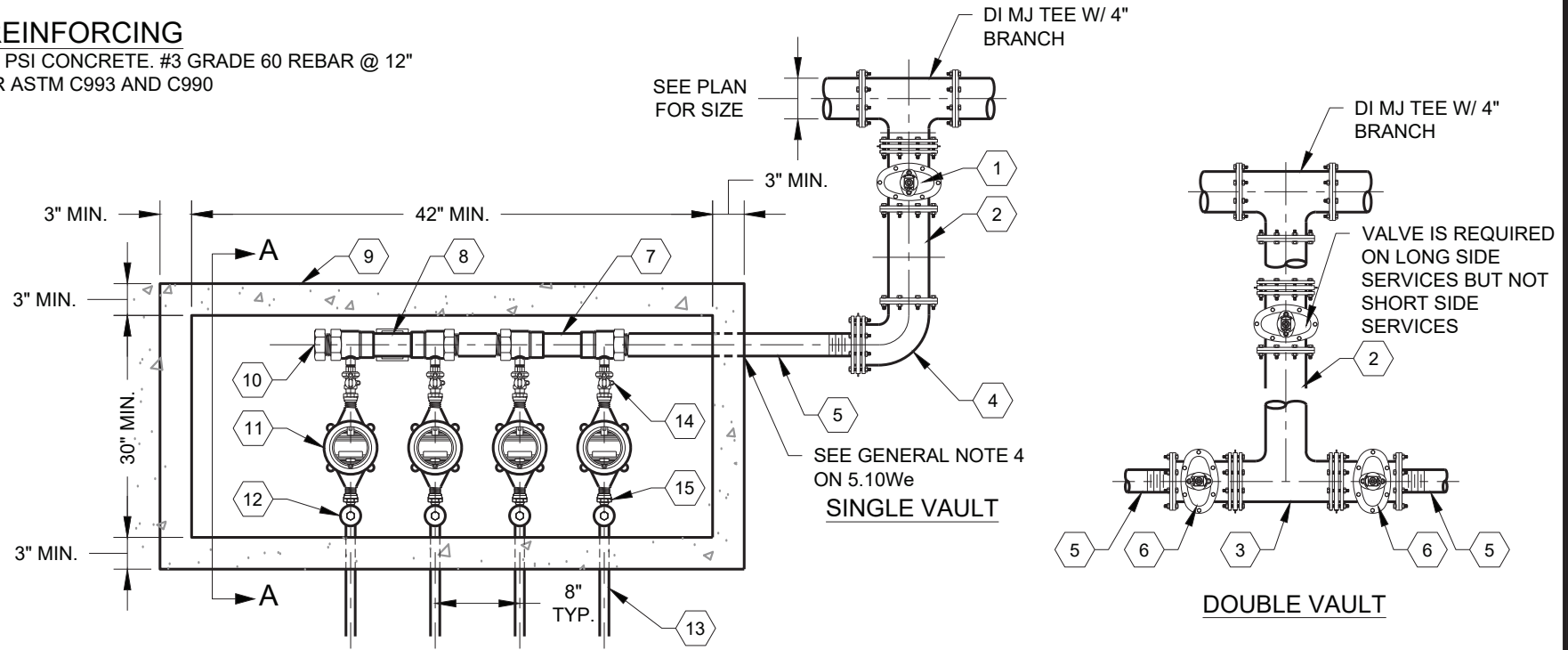

ITEM DESCRIPTION

- ① 4" FOSTER ADAPTER, 4" GATE VALVE W/ BOX
- ② 4" CL. 52 DIP
- ③ 4" x 4" DI MJ TEE WITH RESTRAINT DEVICE ON BRANCH
- ④ 4" x 4" DI MJ 90° BEND, FOSTER ADAPTER AND 4" PLUG TAPPED 2"
- ⑤ 2" PEXa
- ⑥ 4" GATE VALVE W/ BOX, FOSTER ADAPTER AND 4" PLUG TAPPED 2"
- ⑦ FORD M111-574-NL MANIFOLD (OUTLET NO. EQUALS NO. OF METERS)
- ⑧ STEEL PIPE STAND, COOPER B-LINE OR APPROVED EQUAL. 2 REQUIRED.

ITEM DESCRIPTION

- ⑨ PRECAST CONCRETE VAULT; 60" W x 30" D x 36" H MIN INSIDE DIMENSIONS
- ⑩ 2" PLUG
- ⑪ METER. PURCHASED THROUGH DISTRICT. 5/8" x 3/4" WITH RADIO READ ENCODER.
- ⑫ McDONALD 718-207WD RESETTER
- ⑬ 3/4" SERVICE LINE TO TOWN HOME
- ⑭ FORD STRAIGHT BALL METER VALVE B83-242W-NL
- ⑮ 3/4" METER COUPLING (SWIVEL NUT X CTS COMPRESSION), FORD C34-23-Q-NL

3 OR 4 UNITS TOWN HOME METER ASSEMBLY - PLAN

NOT TO SCALE

SEE 5.10We FOR GENERAL TOWN
HOME METER ASSEMBLY NOTES

5.10Wa
02/2026

NOTE:

THE DEVELOPER / CONTRACTOR SHALL PURCHASE ALL METERS FROM GUD. GUD WILL SET THE METERS.

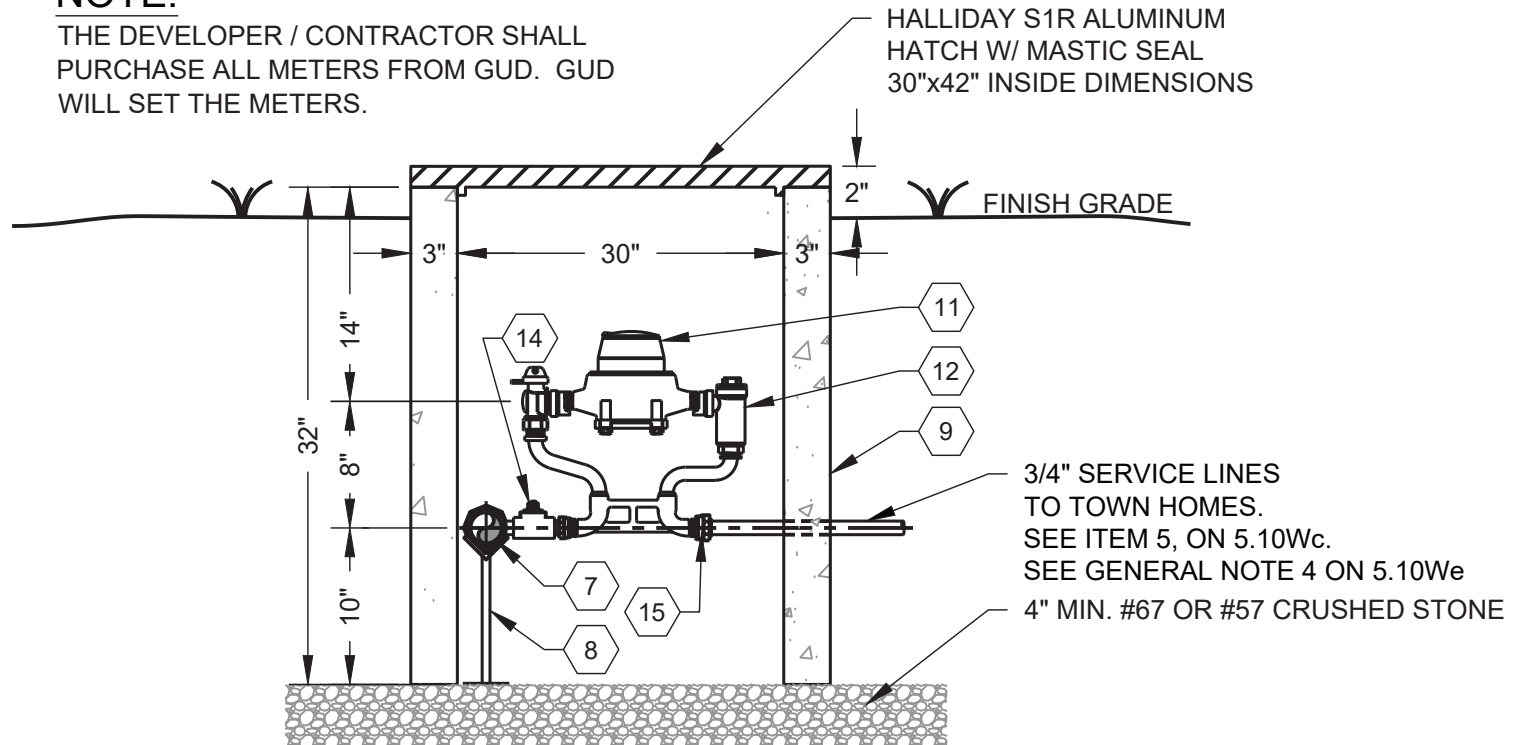

**3 OR 4 UNITS TOWN HOME
METER VAULT - SECTION**

NOT TO SCALE

SEE 5.10We FOR GENERAL TOWN HOME METER ASSEMBLY NOTES

**5.10Wb
02/2026**

VAULT REINFORCING

28 DAY, 5000 PSI CONCRETE. #3 GRADE 60
REBAR @ 12" O.C.E.W. PER ASTM C993 AND C990

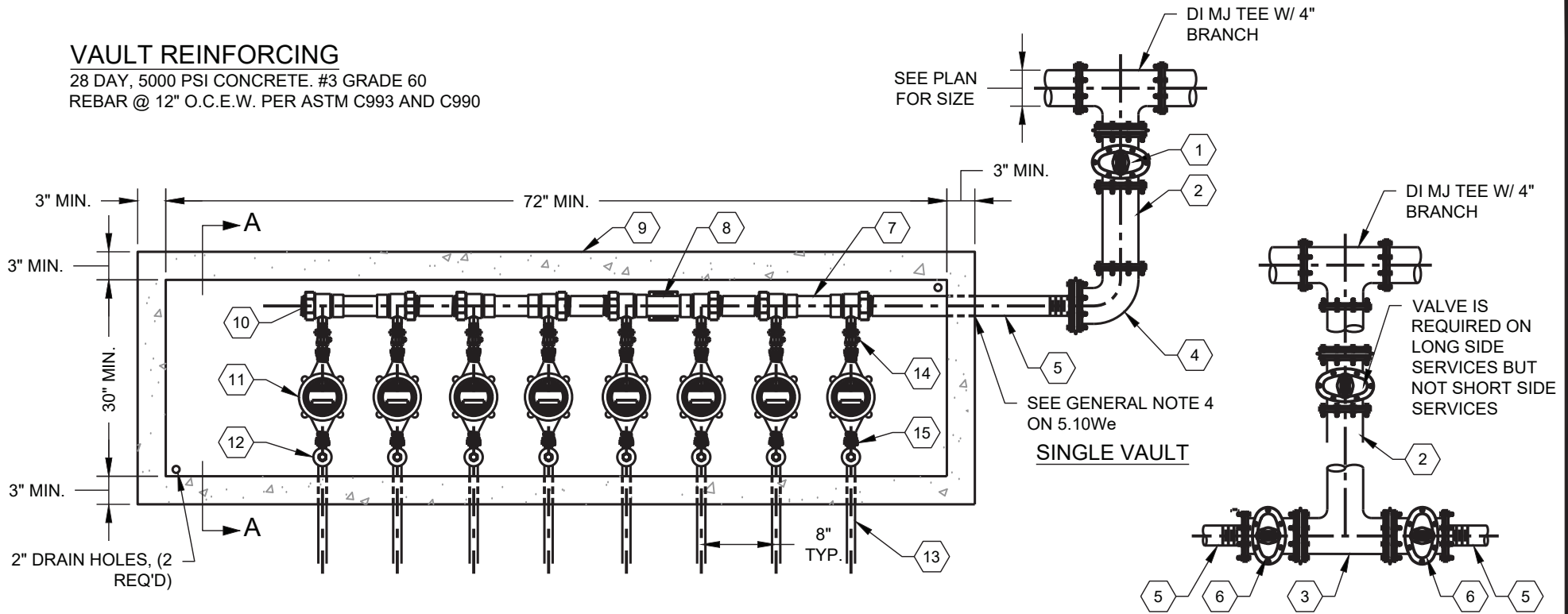

ITEM DESCRIPTION

- ① 4" FOSTER ADAPTER, 4" GATE VALVE W/ BOX
- ② 4" CL. 52 DIP
- ③ 4" x 4" DI MJ TEE WITH RESTRAINT DEVICE ON BRANCH
- ④ 4" x 4" DI MJ 90° BEND, FOSTER ADAPTER AND 4" PLUG TAPPED 2"
- ⑤ PEXa
- ⑥ 4" GATE VALVE W/ BOX, FOSTER ADAPTER AND 4" PLUG TAPPED 2"
- ⑦ FORD M111-574-NL MANIFOLD (OUTLET NO. EQUALS NO. OF METERS)
- ⑧ STEEL PIPE STAND, COOPER B-LINE OR APPROVED EQUAL. 2 REQUIRED.

ITEM DESCRIPTION

- ⑨ PRECAST CONCRETE VAULT; 60" W x 30" D x 36" H MIN INSIDE DIMENSIONS
- ⑩ 2" PLUG
- ⑪ METER. PURCHASED THROUGH DISTRICT. 5/8" x 3/4" WITH RADIO READ ENCODER.
- ⑫ McDONALD 718-207WD RESETTER
- ⑬ 3/4" SERVICE LINE TO TOWN HOME
- ⑭ FORD STRAIGHT BALL METER VALVE B83-242W-NL
- ⑮ 3/4" METER COUPLING (SWIVEL NUT X CTS COMPRESSION), FORD C34-23-Q-NL

DOUBLE VAULT

5 TO 8 UNITS TOWN HOME METER VAULT - PLAN

NOT TO SCALE

SEE 5.10We FOR GENERAL TOWN HOME METER ASSEMBLY NOTES

5.10Wc
02/2026

VAULT REINFORCING

28 DAY, 5000 PSI CONCRETE. #3 GRADE 60
REBAR @ 12" O.C.E.W. PER ASTM C993 AND C990

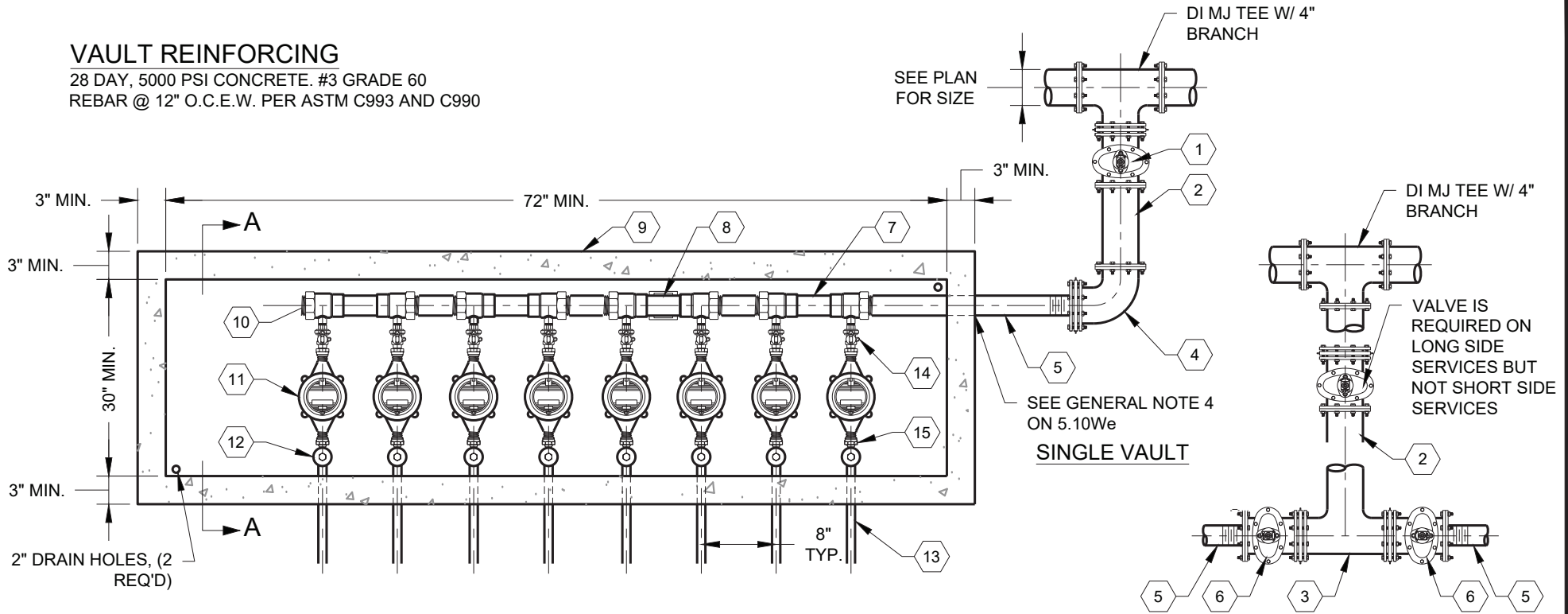

ITEM DESCRIPTION

- 1 4" FOSTER ADAPTER, 4" GATE VALVE W/ BOX
- 2 4" CL. 52 DIP
- 3 4" x 4" DI MJ TEE WITH RESTRAINT DEVICE ON BRANCH
- 4 4" x 4" DI MJ 90° BEND, FOSTER ADAPTER AND 4" PLUG TAPPED 2"
- 5 PEXa
- 6 4" GATE VALVE W/ BOX, FOSTER ADAPTER AND 4" PLUG TAPPED 2"
- 7 FORD M111-574-NL MANIFOLD (OUTLET NO. EQUALS NO. OF METERS)
- 8 STEEL PIPE STAND, COOPER B-LINE OR APPROVED EQUAL. 2 REQUIRED.

ITEM DESCRIPTION

- 9 PRECAST CONCRETE VAULT; 60" W x 30" D x 36" H MIN INSIDE DIMENSIONS
- 10 2" PLUG
- 11 METER. PURCHASED THROUGH DISTRICT. 5/8" x 3/4" WITH RADIO READ ENCODER.
- 12 McDONALD 718-207WD RESETTER
- 13 3/4" SERVICE LINE TO TOWN HOME
- 14 FORD STRAIGHT BALL METER VALVE B83-242W-NL
- 15 3/4" METER COUPLING (SWIVEL NUT X CTS COMPRESSION), FORD C34-23-Q-NL

5 TO 8 UNITS TOWN HOME METER VAULT - PLAN

NOT TO SCALE

SEE 5.10We FOR GENERAL TOWN HOME METER ASSEMBLY NOTES

5.10Wc
02/2026

NOTE:

THE DEVELOPER / CONTRACTOR SHALL PURCHASE ALL METERS FROM GUD. GUD WILL SET THE METERS.

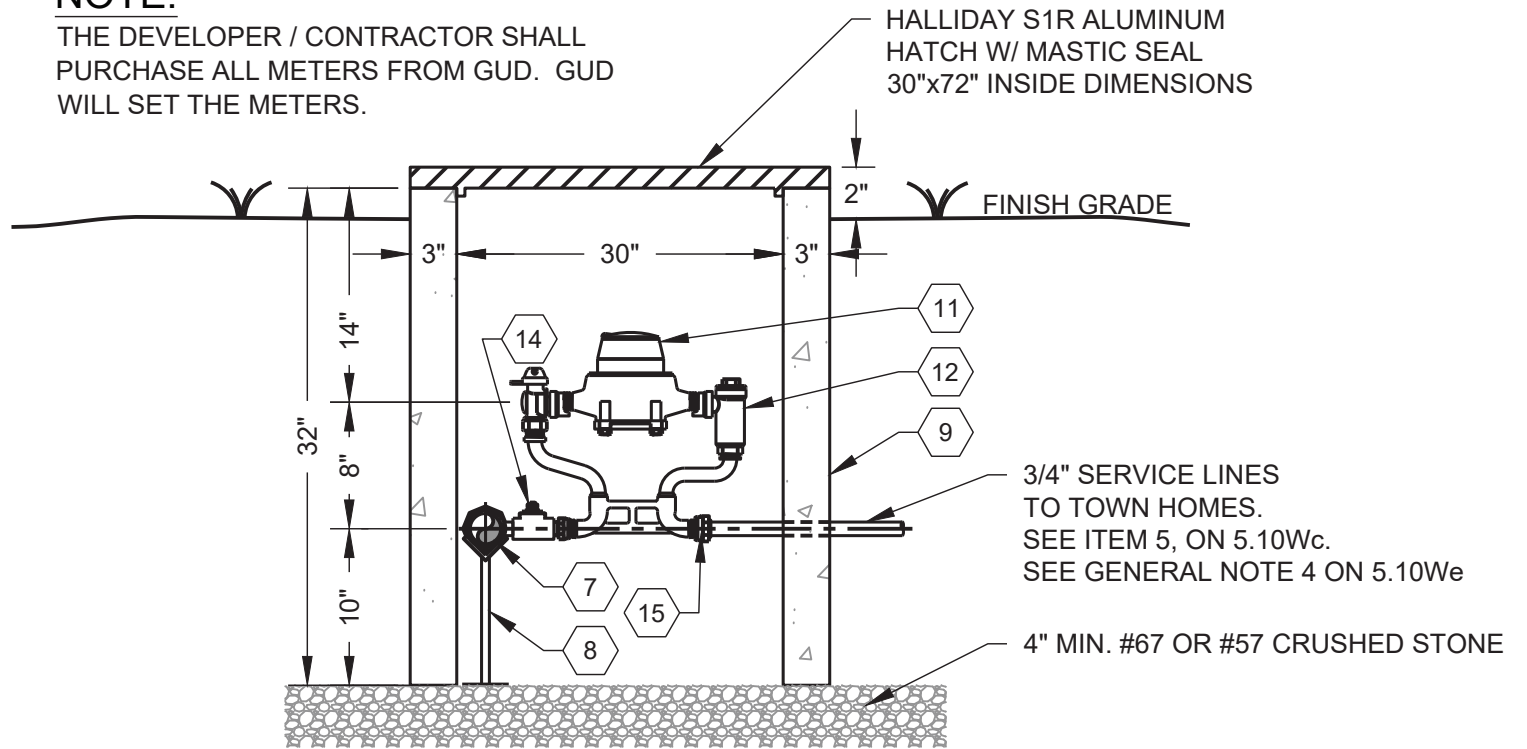

**5 TO 8 UNITS TOWN HOME
METER VAULT (SECTION)**

NOT TO SCALE

SEE 5.10We FOR GENERAL TOWN HOME METER ASSEMBLY NOTES

**5.10Wd
02/2026**

GENERAL 3 TO 8 UNIT TOWN HOME METER ASSEMBLY NOTES

1. MAXIMUM NUMBER OF METERS IN A SINGLE GANG BOX SHALL NOT EXCEED 8. MINIMUM NUMBER OF METERS IN A SINGLE GANG BOX SHALL NOT BE LESS THAN 3.
2. VAULT SHALL BE PRECAST CONCRETE, 5000 PSI MIN. CONCRETE REINFORCEMENT TO BE ASTM C-933, #3 REBAR, GRADE 60. VAULT TO BE EQUIPPED WITH 4 LIFTING ANCHORS.
3. VAULT ACCESS DOOR SHALL BE HALLIDAY SERIES S1R WITH "NO-EMBED FRAME" OR APPROVED EQUAL, WITH AUTO-LOCK HOLD OPEN ARM WITH RELEASE HANDLE; STAINLESS STEEL COMPRESSION SPRING ASSIST; SINGLE LEAF CONSTRUCTION; 300 PSF LOAD RATING; STAINLESS STEEL FRAME. DOOR SHALL BE SIZED TO PROVIDE CLEAR OPENING INTO GANG METER SO THAT ALL METERS ARE EXPOSED WHEN OPENED.
4. SEAL ALL SERVICE OPENINGS WITH NON-SHRINK GROUT OR USE LINK-SEAL STYLE DEVICE.
5. GANG METER ASSEMBLY TO BE SET IN GREENSPACE. PLACEMENT IN STREET, PARKING AREAS, OR SIDEWALK IS NOT PERMITTED.
6. THE DEVELOPER / CONTRACTOR SHALL PURCHASE ALL METERS FROM GLADEVILLE UTILITY DISTRICT. THE DISTRICT WILL SET THE METERS.
7. ALL 4" DIP FOR GANG BOX SERVICES TO BE RESTRAINED.
8. THE SIZE OF THE METER AS SHOWN HEREON HAS BEEN DETERMINED BY THE DEVELOPER OR THE DEVELOPER'S ENGINEER. NEITHER THE GLADEVILLE UTILITY DISTRICT NOR THE DISTRICT'S ENGINEER ACCEPT ANY LIABILITY FOR THE SIZE OR CAPACITY OF THE METER AND APPURTENANCES. THE GLADEVILLE UTILITY DISTRICT DOES NOT WARRANT, EITHER EXPRESSLY OR BY IMPLICATION, THE VOLUME OR PRESSURE OF WATER AVAILABLE FOR FIRE PROTECTION PURPOSES.
9. CONTRACTOR SHALL PAY THE FEE COSTS OF ALL DOMESTIC, IRRIGATION AND FIRE METERS DIRECTLY TO GLADEVILLE UTILITY DISTRICT. GUD WILL ORDER METERS UPON RECEIPT OF PAYMENT AND FURNISH METERS TO THE CONTRACTOR. CONTRACTOR WILL BE REQUIRED TO PICK UP METERS AT GUD OFFICE. GUD IS NOT RESPONSIBLE FOR PROJECT DELAYS ASSOCIATED WITH METER SHIPMENTS.

PRECAST CONCRETE VALVE BOX 57" x 27" x 32" DEEP OR APPROVED EQUAL

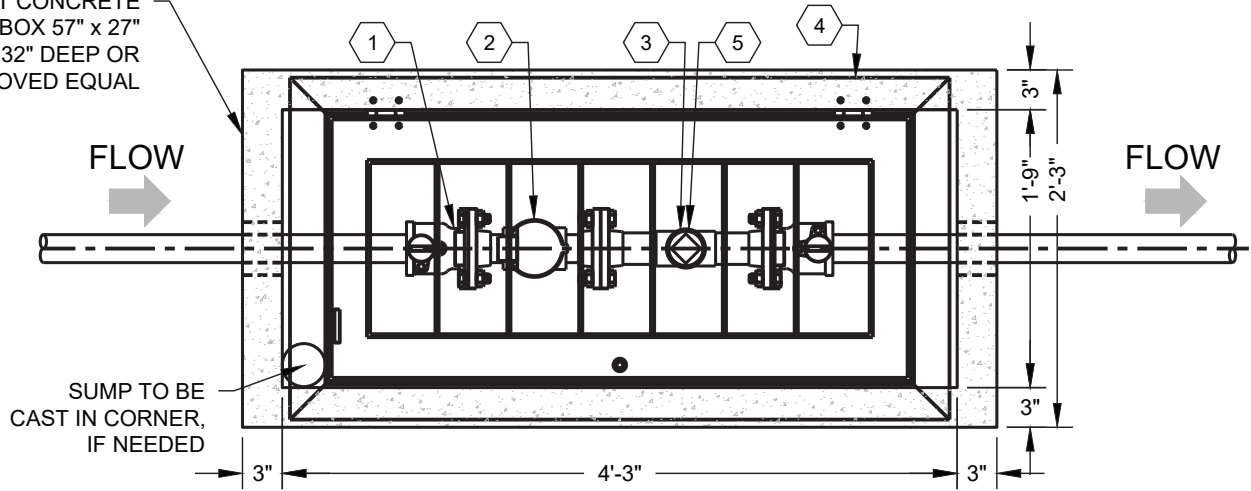

PLAN VIEW

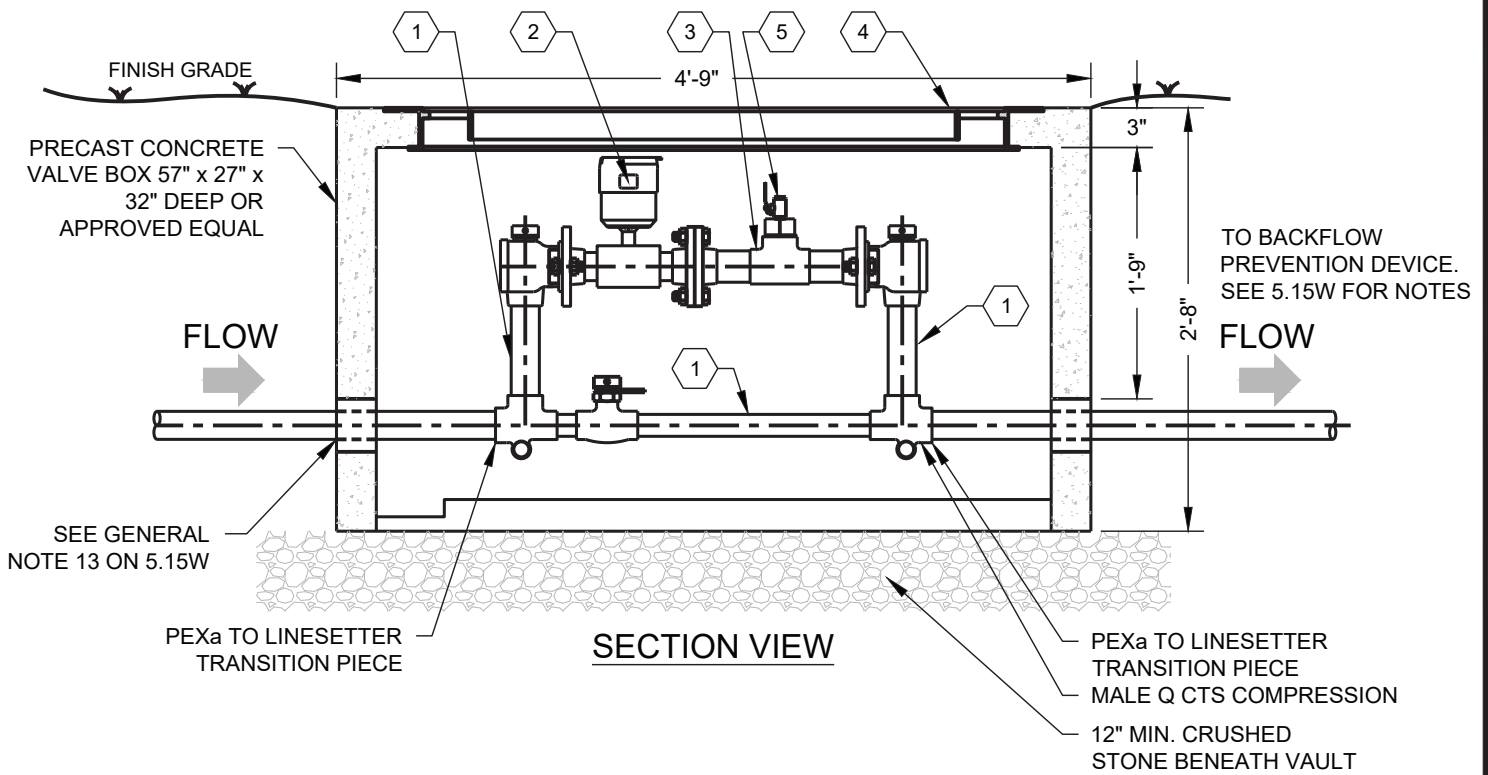

SECTION VIEW

ITEM	DESCRIPTION
1	METER SETTER A.Y. MCDONALD 720B712WWFF 775S(22-7/8) OR FORD VBB77-12B-11-77-22-625-NL
2	FLOW METER ELSTER EVOQ4 (2") ELECTROMAGNETIC OR BADGER RECORDALL M120 (1.5"), METER COUPLING ADAPTERS REQUIRED FOR 1.5" METER (McDONALD NL-710567DH OVAL FL x OVAL FL OR APPROVED EQUAL.
3	TEST PORT 2" FL x 2" FL x 2" SCREWED TEE WITH REMOVABLE PLUG
4	HALLIDAY S1R020044CAAADAAA (OR APPROVED EQUAL) ALUMINUM HATCH 20" x 44" NOMINAL OPENING
5	6" BRASS NIPPLE W/ 2" BALL VALVE

1.5" & 2" METER ASSEMBLY

NOT TO SCALE

SEE 5.15W FOR GENERAL METER ASSEMBLY NOTES

5.11W
02/2026

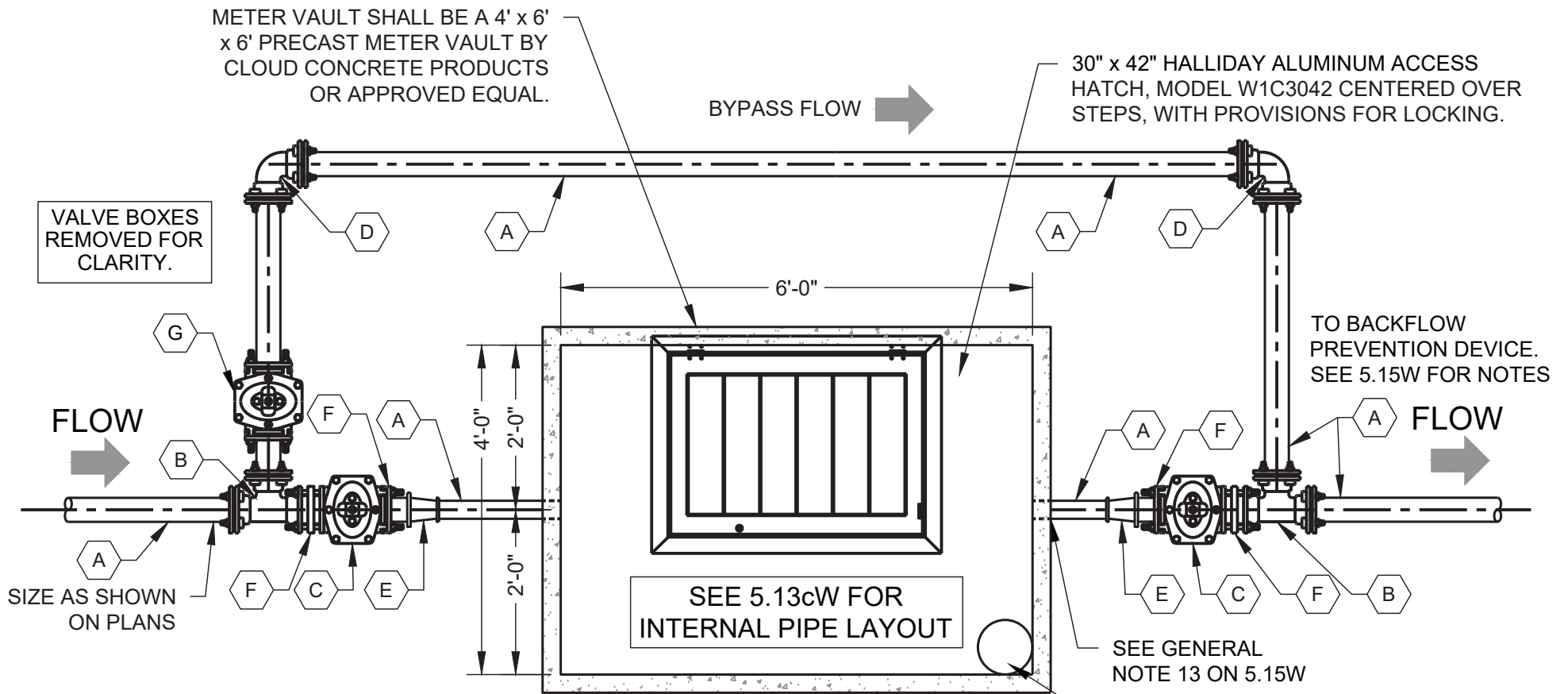

ITEM	DESCRIPTION
(A)	4" CL. 52 DIP
(B)	4"x4" DI MJ TEE
(C)	4" GATE VALVE W/ BOX
(D)	4" 90° DI MJ BEND
(E)	4"x3" DI MJ REDUCER
(F)	3" FOSTER ADAPTER
(G)	4" POST INDICATOR VALVE PAINTED FACTORY BLUE

3" METER ASSEMBLY

NOT TO SCALE

SEE 5.15W FOR GENERAL METER ASSEMBLY NOTES

5.12W
02/2026

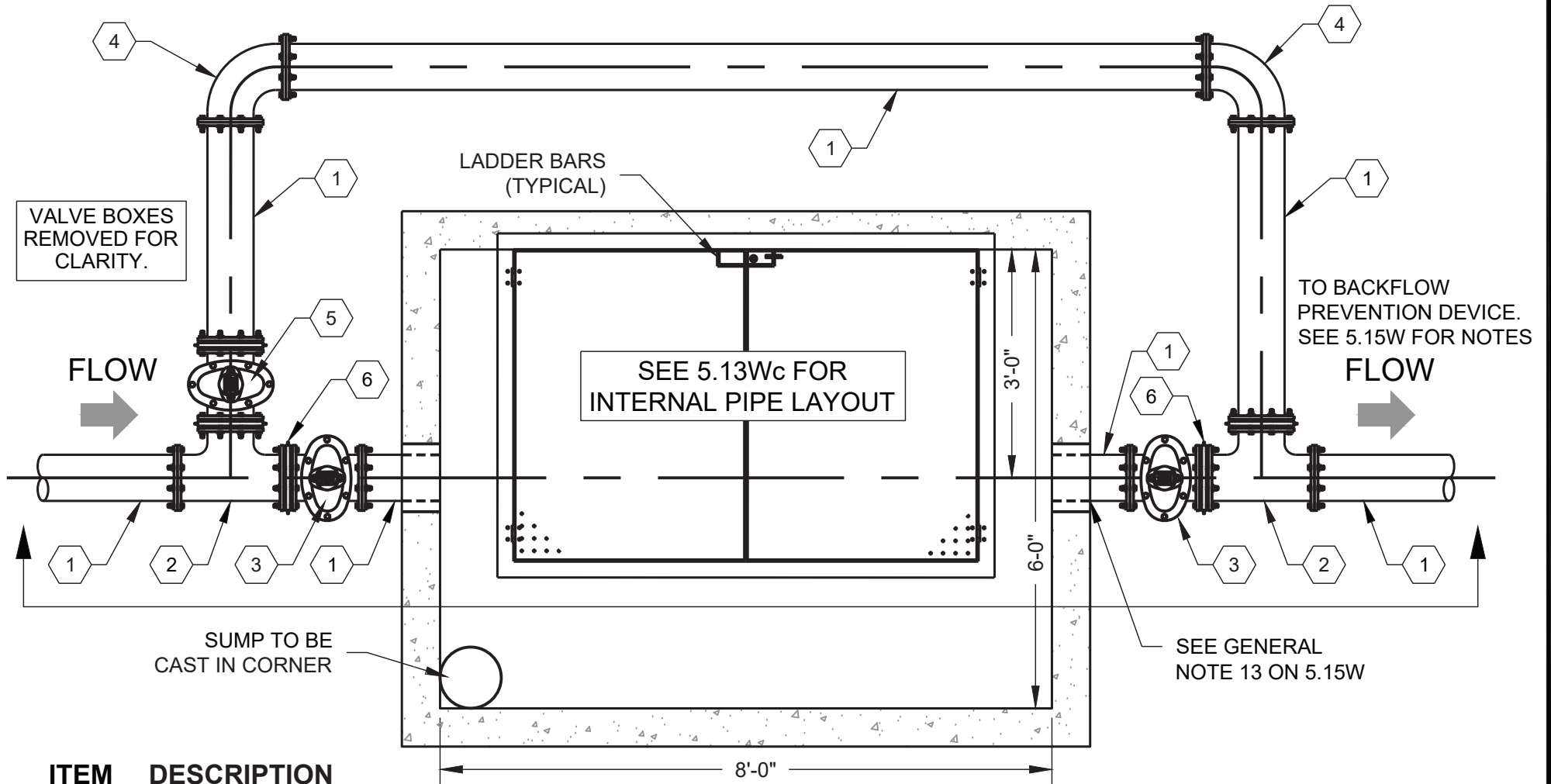

ITEM DESCRIPTION

- ① CL. 52 DIP (SAME SIZE AS METER)
- ② DI MJ TEE
- ③ GATE VALVE WITH VALVE BOX
- ④ 90° DI MJ BEND
- ⑤ POST INDICATOR VALVE, KENNEDY BRAND
- ⑥ FOSTER ADAPTER

4" - 8" FIRE METER ASSEMBLY - PLAN

NOT TO SCALE

ALL MJ. FITTINGS AND VALVES TO INCLUDE MECHANICAL RESTRAINT DEVICES.

SEE 5.15W FOR
GENERAL METER NOTES

5.13Wa
02/2026

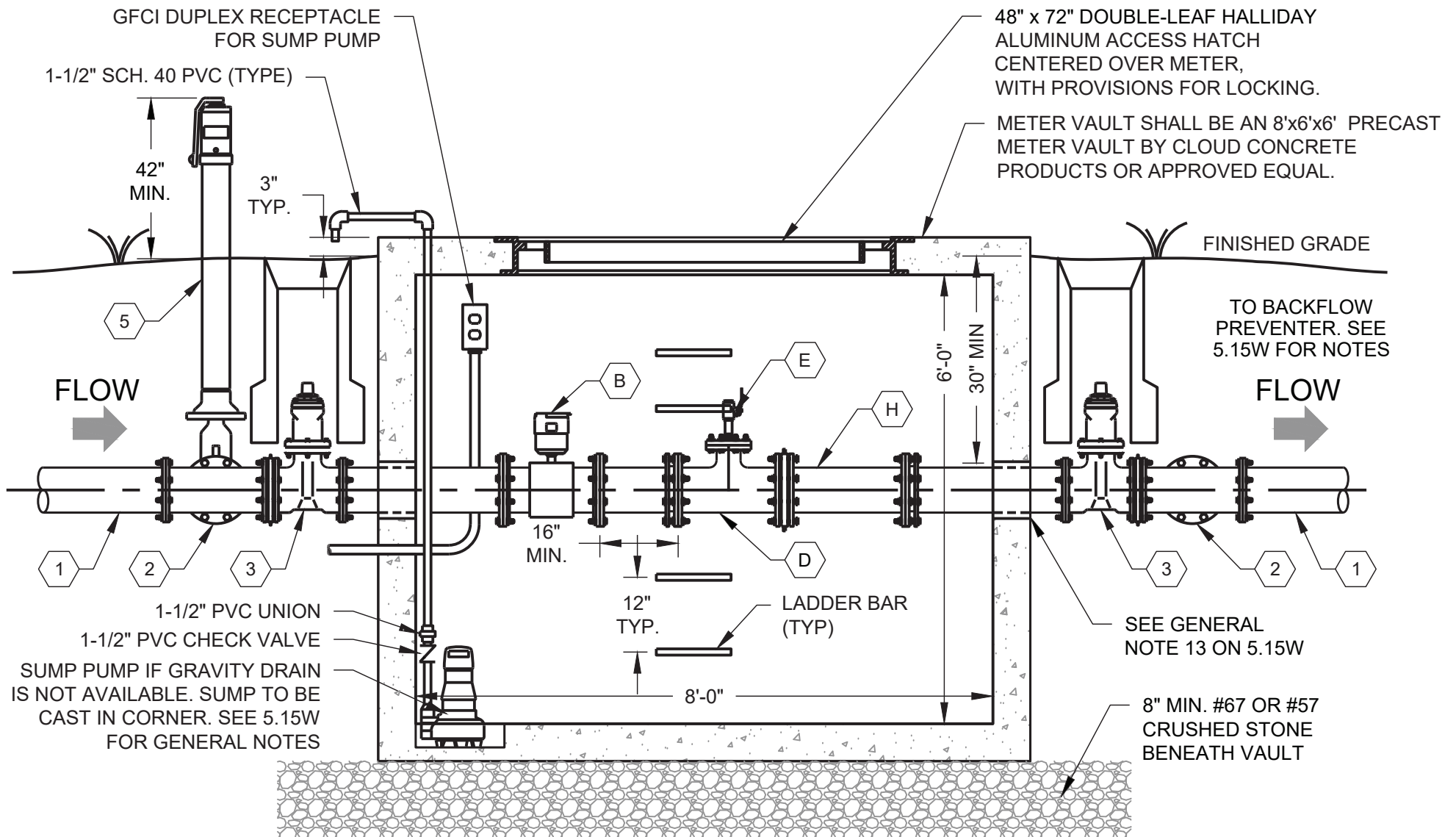

4" - 8" FIRE METER ASSEMBLY - SECTION

NOT TO SCALE

SEE 5.15W FOR GENERAL
METER ASSEMBLY NOTES

5.13Wb
02/2026

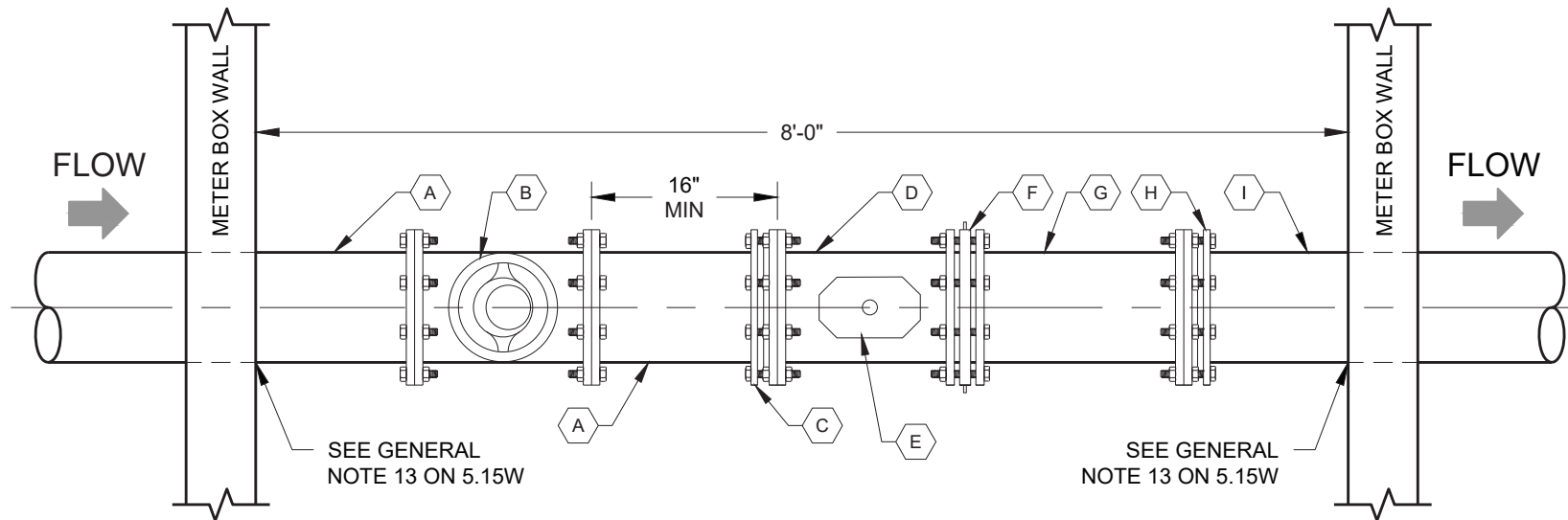

ITEM DESCRIPTION

- (A) FL x PE DIP
- (B) METER (FLANGED) **
- (C) MEGA-LUG RESTRAINT DEVICE
- (D) DI MJ TAPPED TEE (2" TAPPED)
- (E) 6" LONG BRASS NIPPLE W/ 2"
- (F) FOSTER ADAPTER
- (G) DI MJ SLEEVE
- (H) MEGA-LUG RESTRAINT DEVICE
- (I) PE x PE DIP

3" to 8" TYPICAL INTERNAL PIPE LAYOUT

NOT TO SCALE

** ELSTER EV0Q4 FULL FLOW READ METER (3"-8") OR

** BADGER E-SERIES G2 (3"-8")

SEE 5.15W FOR GENERAL
METER ASSEMBLY NOTES

5.13Wc
02/2026

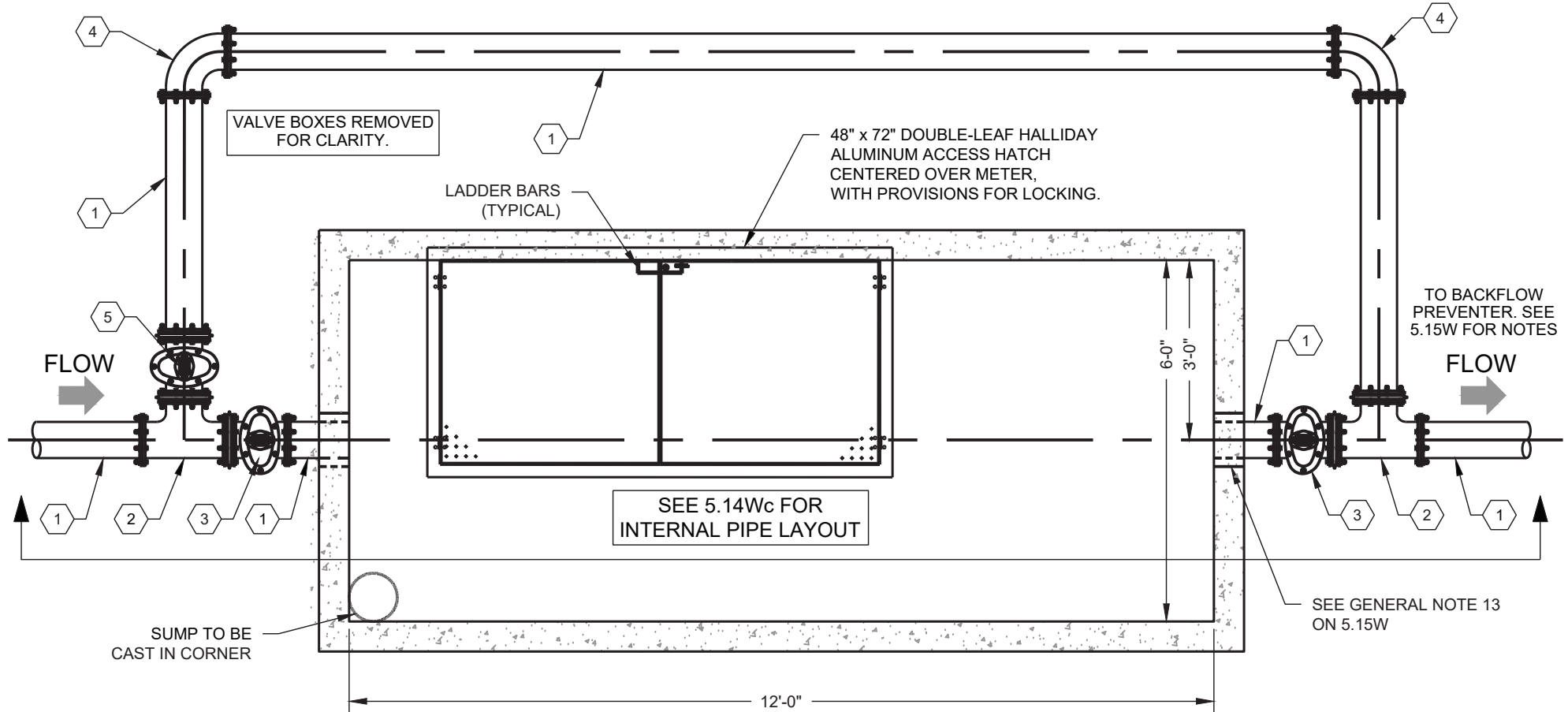

ITEM DESCRIPTION

- ① CL. 52 DIP (SAME SIZE AS METER)
- ② DI MJ TEE
- ③ GATE VALVE WITH VALVE BOX
- ④ 90° DI MJ BEND
- ⑤ POST INDICATOR VALVE, KENNEDY BRAND
- ⑥ FOSTER ADAPTER

10" FIRE METER ASSEMBLY - PLAN

NOT TO SCALE

ALL MJ. FITTINGS AND VALVES TO INCLUDE MECHANICAL RESTRAINT DEVICES.

SEE 5.15W FOR GENERAL METER ASSEMBLY NOTES

5.14Wa
02/2026

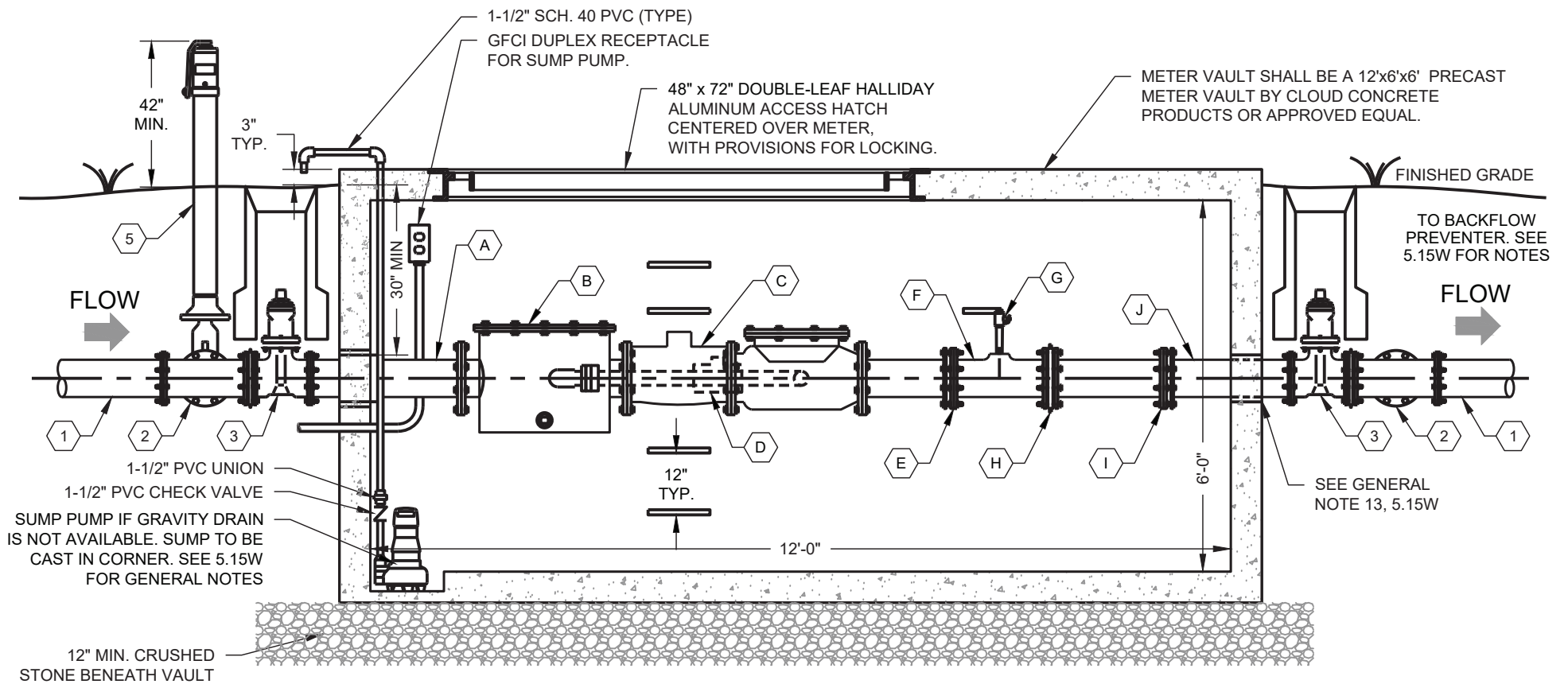

10" FIRE METER ASSEMBLY - SECTION

NOT TO SCALE

SEE 5.15W FOR
GENERAL METER NOTES

5.14Wb
02/2026

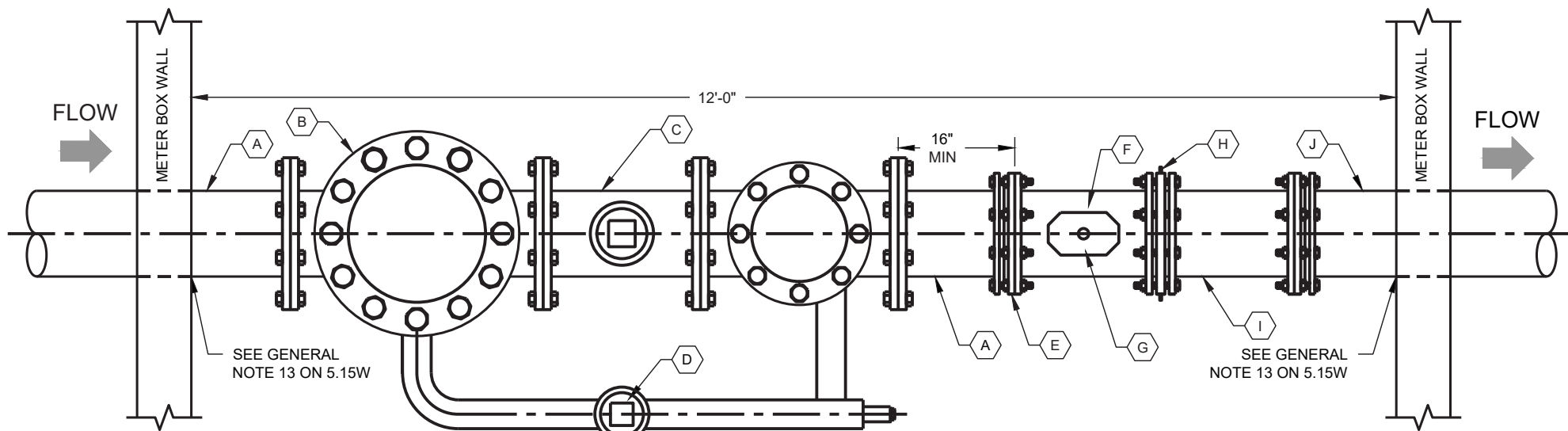

ITEM DESCRIPTION

- (A) FL x PE DIP
- (B) FIRE METER STRAINER
- (C) 10" BADGER RECORDALL FIRE SERIES ASSEMBLY
- (D) TURBINE METER BYPASS
- (E) MEGA-LUG RESTRAINT DEVICE

ITEM DESCRIPTION

- (F) DI MJ TAPPED TEE (2" TAPPED)
- (G) 6" LONG BRASS NIPPLE W/ 2" BALL VALVE
- (H) FOSTER ADAPTER
- (I) DI MJ SLEEVE
- (I) MEGA-LUG RESTRAINT DEVICE
- (J) PE x PE DIP

ALL MJ. FITTINGS AND VALVES TO INCLUDE MECHANICAL RESTRAINT DEVICES.

**10" FIRE METER
INTERNAL PIPE LAYOUT**

NOT TO SCALE

SEE 5.15W FOR GENERAL
METER ASSEMBLY NOTES

**5.14Wc
02/2026**

GENERAL METER ASSEMBLY NOTES: (1.5" - 10")

1. THE CONCRETE VAULT FOR 1.5" - 10" METER ASSEMBLIES SHALL BE FURNISHED WITH A PRE-CAST METER VAULT AS SPECIFIED HEREON.
2. 1.5" AND 2" METER ASSEMBLIES SHALL USE A S1R 20"x44" DROP-IN ALUMINUM HATCH. 3" AND 4" METER ASSEMBLIES SHALL USE A S2R 30"x42" CAST IN PLACE HATCH. 6" METER ASSEMBLIES SHALL USE A S2R 48"x72" CAST IN PLACE HATCH. HATCHES FOR METERS GREATER THAN 2" SHALL BE CENTERED OVER METER ASSEMBLY.
3. IF A POSITIVE, ADEQUATELY SIZED DRAIN TO DAYLIGHT CANNOT BE PROVIDED DIRECTLY FROM THE VAULT, A SUMP SHALL BE CAST INTO THE BASE OF THE VAULT, AND THE VAULT INSTALLATION SHALL BE COMPLETE WITH A SUMP PUMP SET AS REQUIRED, WITH PIPED DISCHARGE TO DAYLIGHT AT AN APPROVED LOCATION. SUMP PUMP SHALL BE A ZOELLER MODEL 63 (OR APPROVED EQUAL). 0.3 HP, 110 VAC, 1Ø, AUTOMATIC, 10' UL LISTED CORD WITH 3-WIRE GROUNDED PLUG, 1-1/2" DISCHARGE, 14 GPM @ 20' HEAD.
4. IT SHALL BE THE DEVELOPER'S RESPONSIBILITY TO MEET AND PROVIDE ANY AND ALL POWER REQUIREMENTS ASSOCIATED WITH THE SUMP PUMP IN THE METER VAULTS, IF APPLICABLE. AT A MINIMUM A GFCI DUPLEX RECEPTACLE A 20 AMP DEDICATED CIRCUIT MOUNTED INSIDE VAULT IN A WEATHERPROOF ENCLOSURE WITH WHILE-IN-USE COVER SHALL BE PROVIDED FOR THE SUMP PUMP. IN NO CASE SHALL THE GLADEVILLE UTILITY DISTRICT BE RESPONSIBLE FOR PROVIDING POWER TO THESE INSTALLATIONS.
5. PRIOR TO BEGINNING THE INSTALLATION OF THE WATER LINE AND APPURTENANCES, THE CONTRACTOR SHALL OBTAIN THE APPROVAL OF THE WILSON CO. FIRE MARSHALL'S OFFICE. IF THE FIRE MARSHALL'S OFFICE REQUIRES ANY CHANGES OR ADJUSTMENTS TO THE DETAILS AS SHOWN HEREON, THE GLADEVILLE UTILITY DISTRICT SHALL BE NOTIFIED IMMEDIATELY SO THAT THE APPROPRIATE REVISIONS MAY BE MADE TO THE PLAN.
6. COORDINATE ALL WORK AS SHOWN HEREON WITH THE GLADEVILLE UTILITY DISTRICT, INCLUDING CONNECTIONS TO EXISTING OR PROPOSED LINES AND THE CONSTRUCTION OF THE PUBLIC IMPROVEMENTS, IF APPLICABLE.
7. FOR THE PUBLIC PORTION OF THE PROPOSED GUD LINE, ALL PIPING SHALL BE NEW DUCTILE IRON PIPE, ANSI THICKNESS CLASS 52, AND ALL MECHANICAL JOINT FITTINGS SHALL BE NEW DUCTILE IRON FITTINGS WITH MEGA-LUG GLANDS.
8. ALL VALVES WITH MECHANICAL JOINTS SHALL HAVE MEGA-LUG GLANDS. ALL PUSH-ON JOINTS IN THE METER ASSEMBLY LAYOUT SHALL INCLUDE RESTRAINT GASKETS.
9. FOR CLARITY, PIPING AND METER SUPPORTS HAVE NOT BEEN SHOWN HEREON. THE CONTRACTOR SHALL BE SOLELY RESPONSIBLE FOR FURNISHING AND INSTALLING ALL REQUIRED SUPPORTS, BUT NO SUPPORTS SHALL BE INSTALLED PRIOR TO APPROVAL BY THE DISTRICT.
10. THE TAP FOR METER TESTING PURPOSES SHALL INCLUDE A 2" TAP AND 2" BALL VALVE WITH A 2" X 6" LONG BRASS NIPPLE, THREADED ON BOTH ENDS TO FACILITATE CONNECTION OF THE METER TESTING APPARATUS. COORDINATE WITH THE GLADEVILLE UTILITY DISTRICT.
12. CONTRACTOR SHALL VERIFY VERTICAL LOCATIONS OF PIPE ENTRY HOLES WITH EXTERNAL PIPING. HAMMERED OR OVER-SIZED HOLES ARE NOT PERMITTED AND VAULT WILL BE REJECTED.
13. ANNULAR OPENINGS SHALL BE SEALED WITH LINK-SEAL STYLE DEVICES OR NON-SHRINK GROUT TO PREVENT GROUND WATER LEAKAGE INTO METER VAULT.
14. ALL FIRE METERS SHALL BE FOLLOWED BY A DOUBLE CHECK VALVE PER GUD REQUIREMENTS. NO CONNECTION IS ALLOWED BETWEEN METER AND BACKFLOW DEVICE.
15. ALL DOMESTIC AND IRRIGATION METERS SHALL BE FOLLOWED BY A REDUCED PRESSURE BACKFLOW PREVENTER IN AN ABOVEGROUND HEATED ENCLOSURE ON A CONCRETE PAD PER GUD REQUIREMENTS. NO CONNECTION IS ALLOWED BETWEEN METER AND BACKFLOW DEVICE.
16. THE SIZE OF THE METER AS SHOWN HEREON HAS BEEN DETERMINED BY THE DEVELOPER OR THE DEVELOPER'S ENGINEER. NEITHER THE GLADEVILLE UTILITY DISTRICT NOR THE DISTRICT'S ENGINEER ACCEPT ANY LIABILITY FOR THE SIZE OR CAPACITY OF THE METER AND APPURTENANCES. THE GLADEVILLE UTILITY DISTRICT DOES NOT WARRANT, EITHER EXPRESSLY OR BY IMPLICATION, THE VOLUME OR PRESSURE OF WATER AVAILABLE FOR FIRE PROTECTION PURPOSES.
17. CONTRACTOR SHALL PAY THE FEE COSTS OF ALL DOMESTIC, IRRIGATION AND FIRE METERS DIRECTLY TO GLADEVILLE UTILITY DISTRICT. GUD WILL ORDER METERS UPON RECEIPT OF PAYMENT AND FURNISH METERS TO THE CONTRACTOR. CONTRACTOR WILL BE REQUIRED TO PICK UP METERS AT GUD OFFICE. GUD IS NOT RESPONSIBLE FOR PROJECT DELAYS ASSOCIATED WITH METER SHIPMENTS.

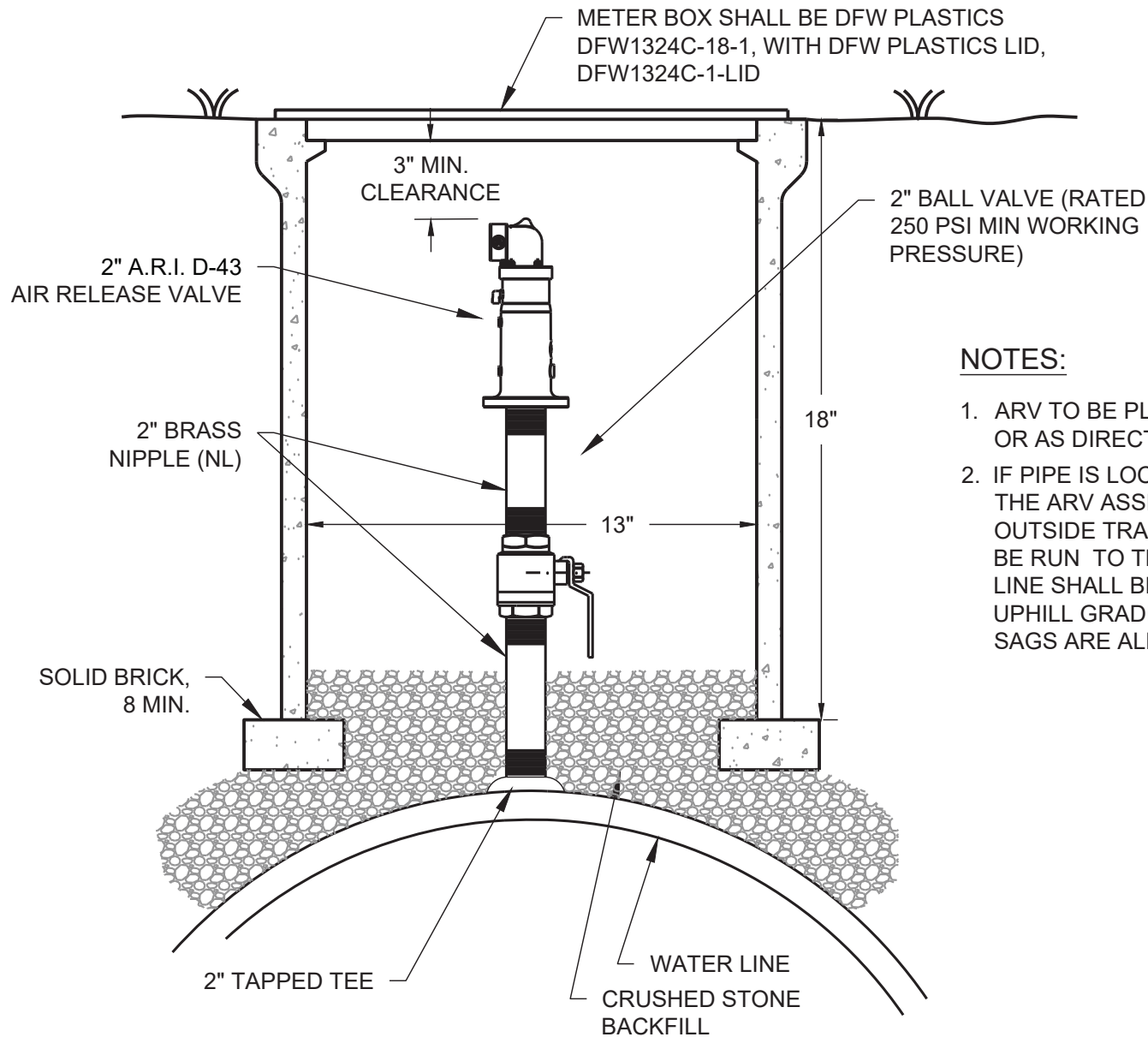

NOTES:

1. ARV TO BE PLACED AT HIGH POINT IN PROFILE OR AS DIRECTED BY GUD.
2. IF PIPE IS LOCATED IN TRAFFIC AREAS, THEN THE ARV ASSEMBLY SHALL BE INSTALLED OUTSIDE TRAFFIC AREAS. 2" PEXa PIPE SHALL BE RUN TO THE TAP ON THE WATER LINE. 2" LINE SHALL BE INSTALLED TO MAINTAIN AN UPHILL GRADIENT TO THE ARV. NO DIPS OR SAGS ARE ALLOWED.

2" AIR RELEASE ASSEMBLY

NOT TO SCALE

5.16W
02/2026

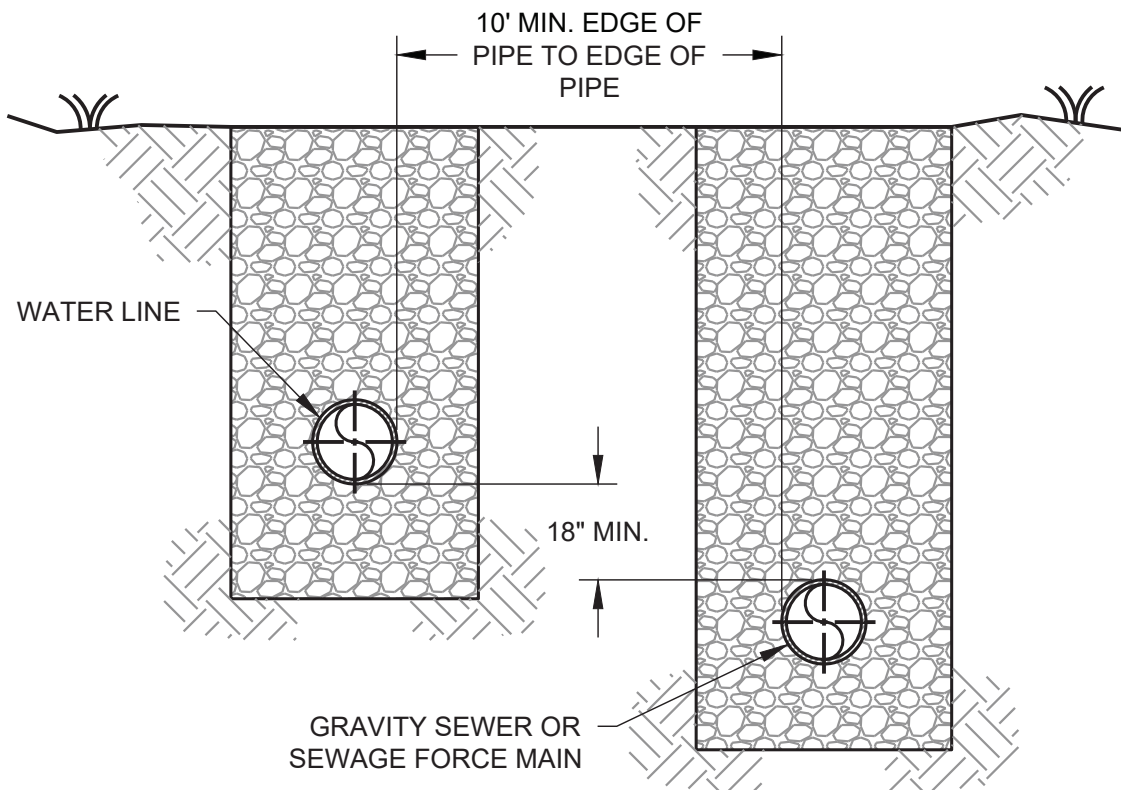

UTILITY SEPARATION DETAIL

NOT TO SCALE

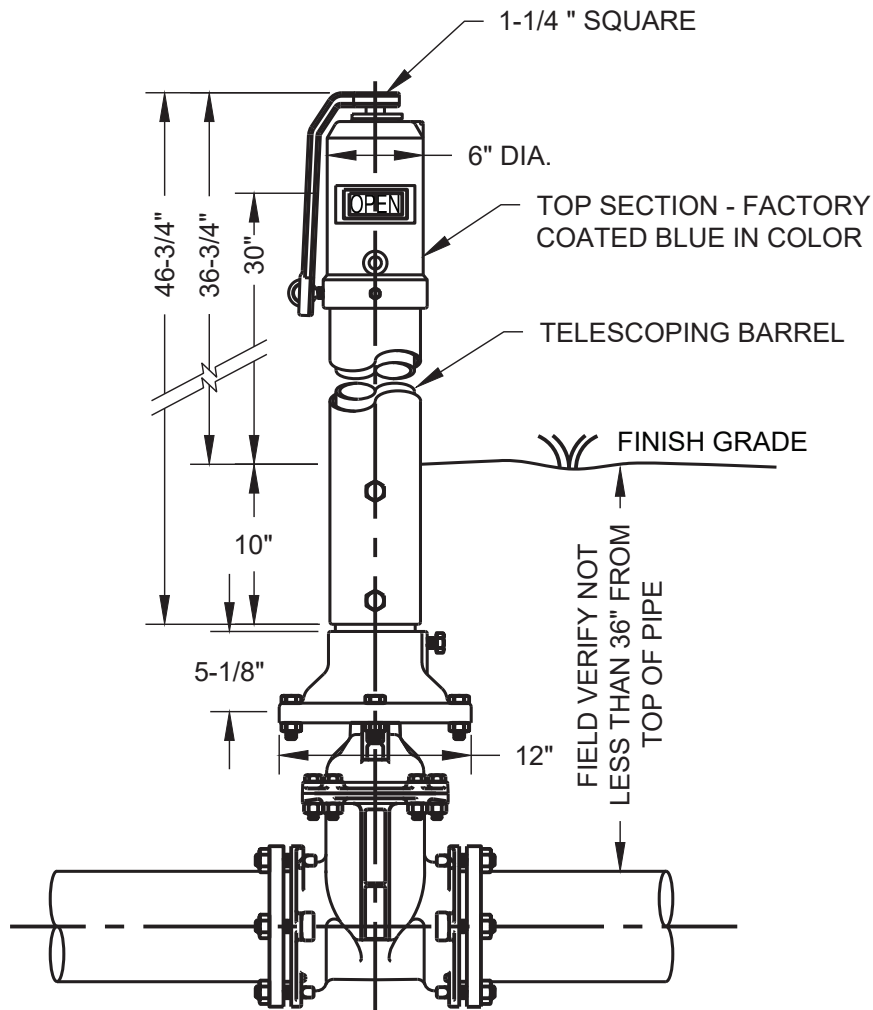

FIELD ADJUSTMENT INSTRUCTIONS

1. REMOVE THE TOP SECTION FROM THE TOP OF THE INDICATOR POST ASSEMBLY.
2. LOOSEN THE TELESCOPING BARREL SCREWS AND ADJUST BARREL TO THE GROUND LINE.
3. CUT THE 1" SQUARE STEM AT A DISTANCE OF 9" ABOVE THE TOP OF THE BARREL END.
4. SET THE "OPEN" AND "SHUT" TARGETS FOR THE APPROPRIATE VALVE SIZE. NORMALLY IN A "SHUT" STATUS.
5. REATTACH THE TOP SECTION TO THE TOP OF THE INDICATOR POST ASSEMBLY.
6. USE WHERE DIRECTED BY G.U.D.

POST INDICATOR VALVE
 NOT TO SCALE

5.18W
 02/2026

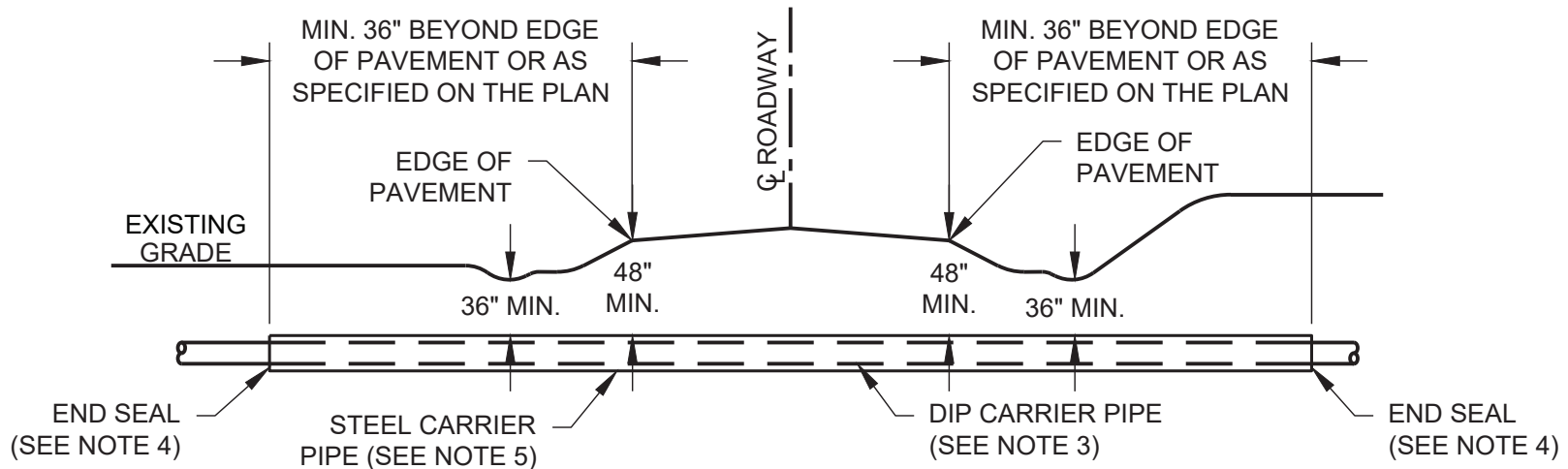

NOTES:

1. CASING SHALL EXTEND A MINIMUM OF 3' BEYOND THE EDGE OF PAVEMENT (OR AS SPECIFIED ON THE PLAN SHEETS)
2. BORED CROSSINGS SHALL BE PERMITTED AND INSTALLED TO MEET THE REQUIREMENTS OF TENNESSEE DEPARTMENT OF TRANSPORTATION AND/OR THE GOVERNING HIGHWAY DEPARTMENT.
3. CARRIER PIPE SHALL BE CENTERED IN THE CASING PIPE. CARRIER PIPE SHALL BE INSTALLED USING CASING SPACERS, PER DETAIL 5.20W. USE LOCKING GASKETS IN BELL JOINTS OF THE CARRIER PIPE.
4. ENDS OF CASING PIPE SHALL BE SEALED UTILIZING NEOPRENE RUBBER WRAP AROUND SEALS WITH STAINLESS STEEL BANDS.
5. REFER TO SPECIFICATION FOR CASING PIPE THICKNESS AND DIAMETER.

BORE AND JACK FOR HIGHWAYS

NOT TO SCALE

5.19W
02/2026

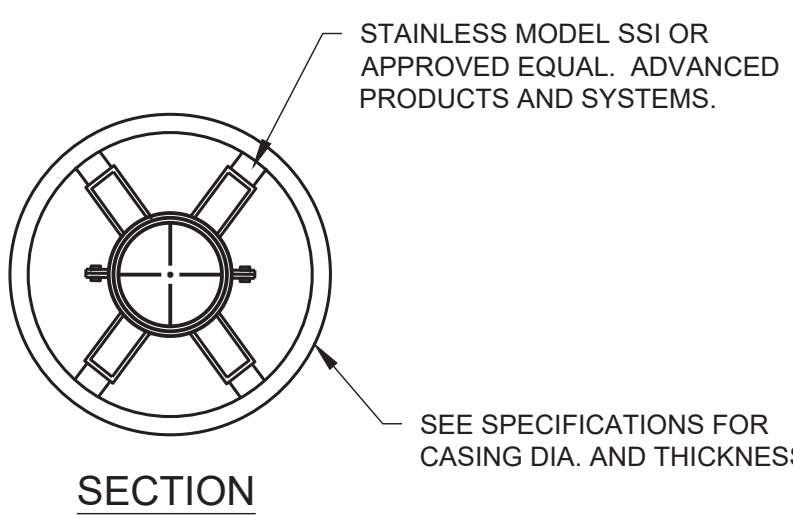

NEOPRENE RUBBER WRAP AROUND END SEALS W / STAINLESS STEEL BANDS WITH WORM SCREWS. ADVANCE PRODUCTS & SYSTEMS, INC. TYPE "AW", PIPELINE SEAL AND INSULATOR, INC, TYPE "KG" OR APPROVED EQUAL.

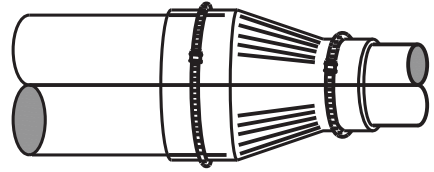

END SEAL

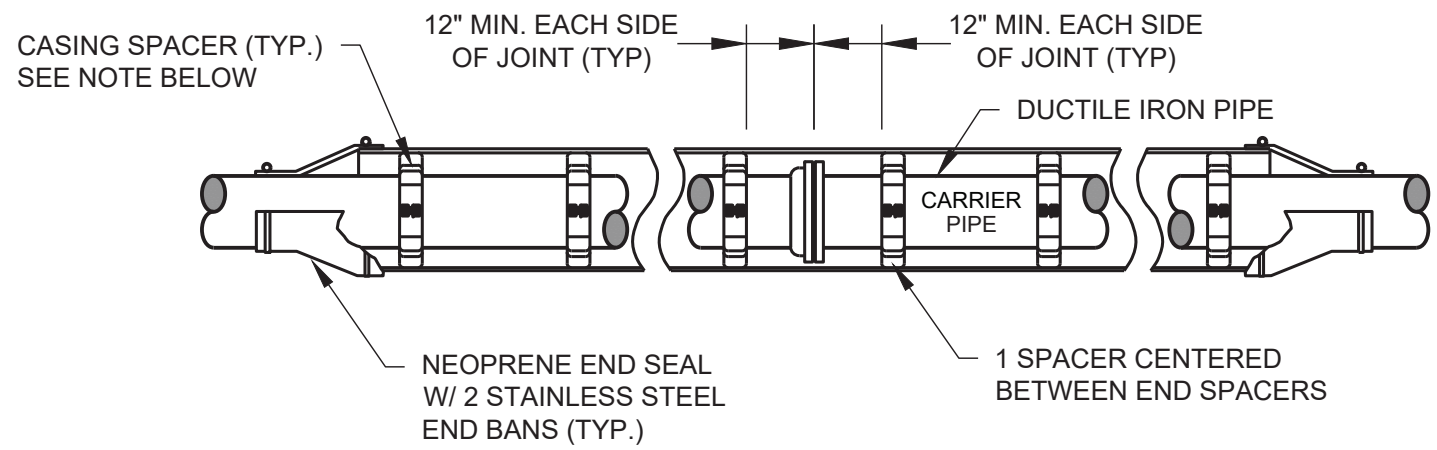

ELEVATION

NOTE:
MINIMUM REQUIREMENT OF 3 CASING SPACERS PER 20' SECTIONS OF PIPE.

STANDARD CASING SPACER
AND END SEALS

NOT TO SCALE

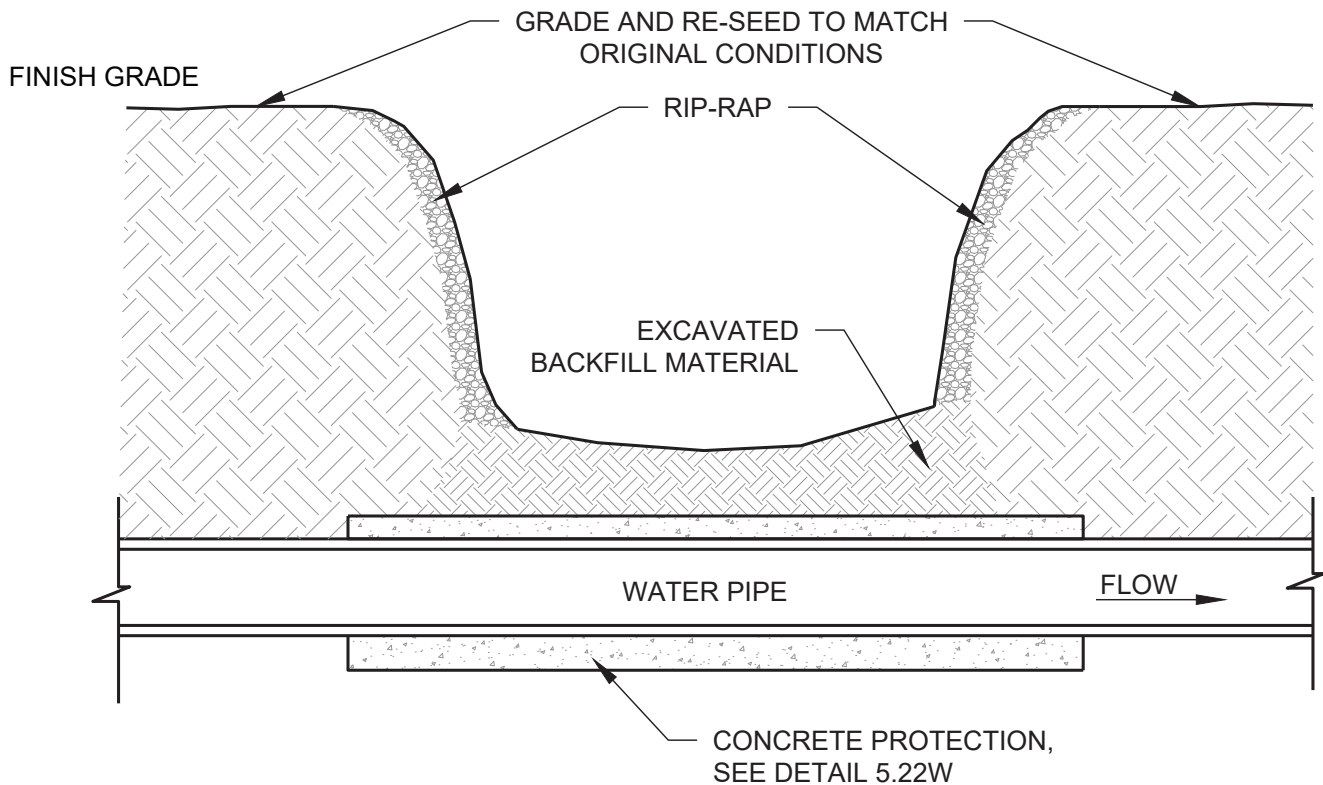

NOTE:

FOR A NO-BLAST CREEK CROSSING, CROSSING IS TO BE PERFORMED AS FOLLOWS.

1. LINE DRILL ON 8" CENTER-TO-CENTER ACROSS THE CREEK ALONG EACH EDGE OF PROPOSED DITCH.
2. PERFORM ADDITIONAL LINE DRILLING BETWEEN PROPOSED DITCH EDGES AS NEEDED.
3. BREAK ROCK BETWEEN LINE DRILL HOLES WITH HOE-RAM AND REMOVE FRACTURED ROCK AS NEEDED TO ALLOW FOR PIPE INSTALLATION.
4. INSTALL PIPE AT GRADE AND ENCASE IN CONCRETE PER DETAIL 5.22W. TOP OF CONCRETE TO EXTEND 8" ABOVE TOP OF PIPE. (ENCASEMENT WIDTH TO BE POURED THE WIDTH OF THE TRENCH WITH A MINIMUM OF 4" ON EACH SIDE.)
5. BACKFILL OVER CONCRETE WITH ORIGINAL EXCAVATED MATERIAL.
6. GRADE CREEK BANK AND CREEK BOTTOM TO MATCH ORIGINAL GRADE.
7. RE-SEED BANKS TO MATCH ORIGINAL CONDITIONS.

CREEK CROSSING

NOT TO SCALE

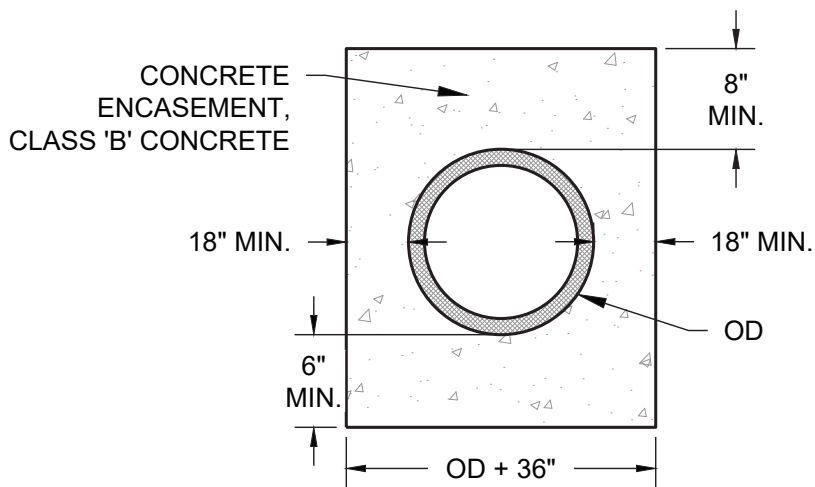

NOTES:
 CONCRETE TO BE POURED TO LIMITS OF TRENCH EXCAVATION. SEE DETAILS BELOW.

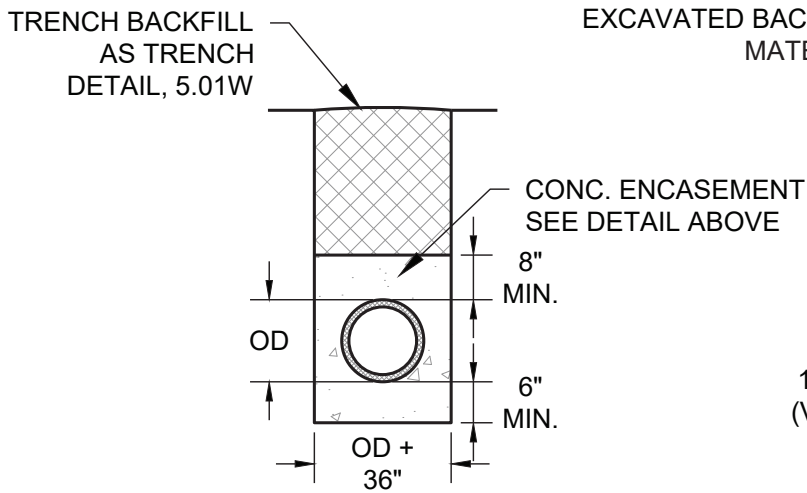

**STANDARD
 CONCRETE ENCASEMENT**

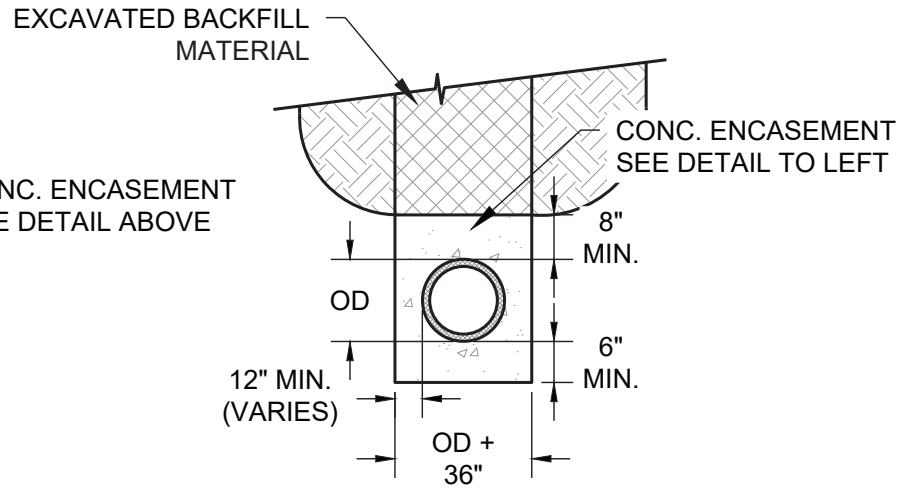

**CREEK BOTTOM CONCRETE
 ENCASEMENT**

CONCRETE PROTECTION FOR UTILITY LINES

NOT TO SCALE

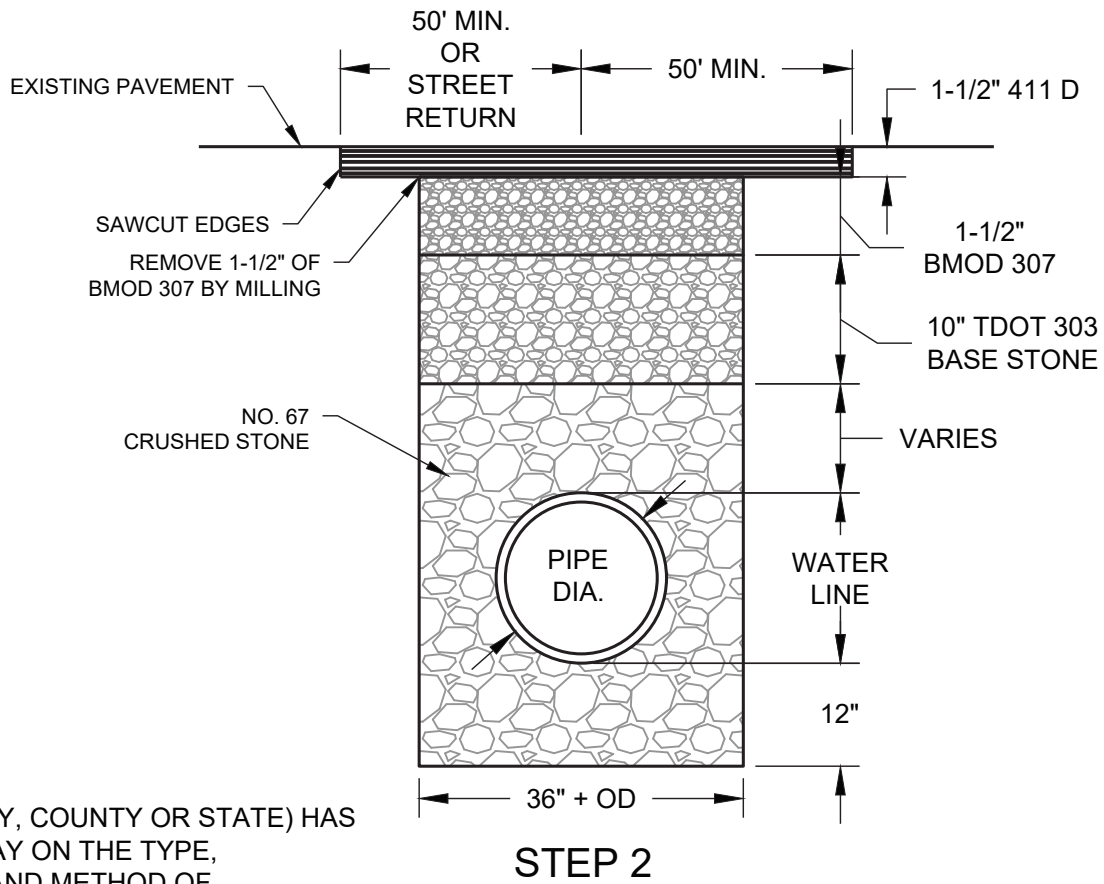
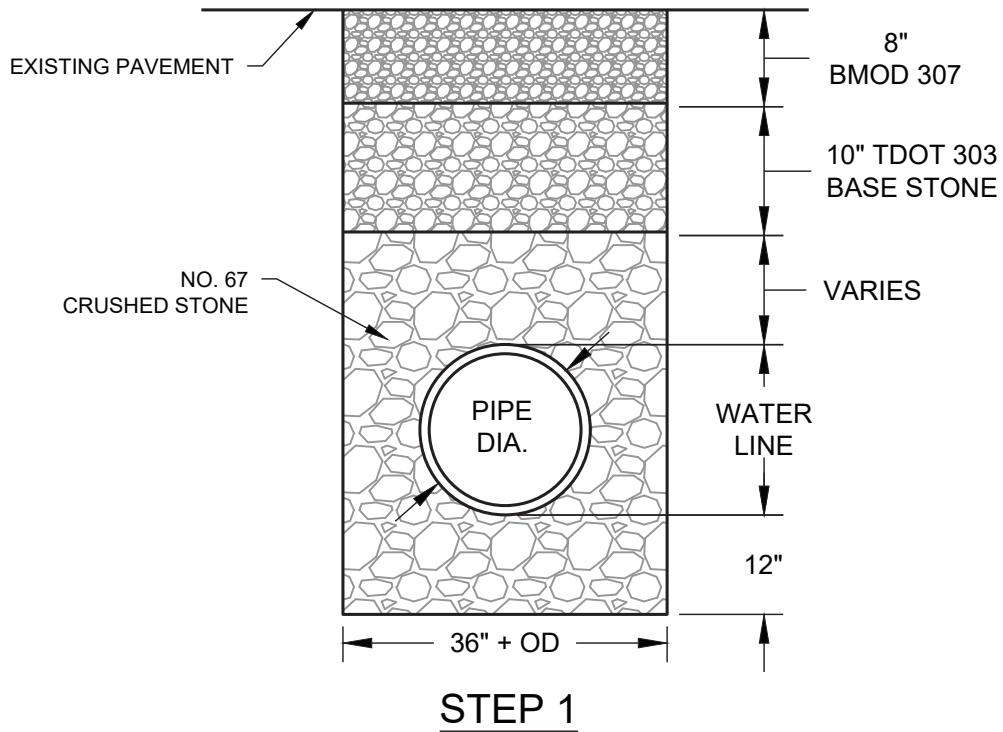

NOTE:
THE AHJ (CITY, COUNTY OR STATE) HAS
THE FINAL SAY ON THE TYPE,
THICKNESS AND METHOD OF
PAVEMENT REPAIR TO BE USED.

PAVEMENT REPAIR

NOT TO SCALE

5.23W
02/2026

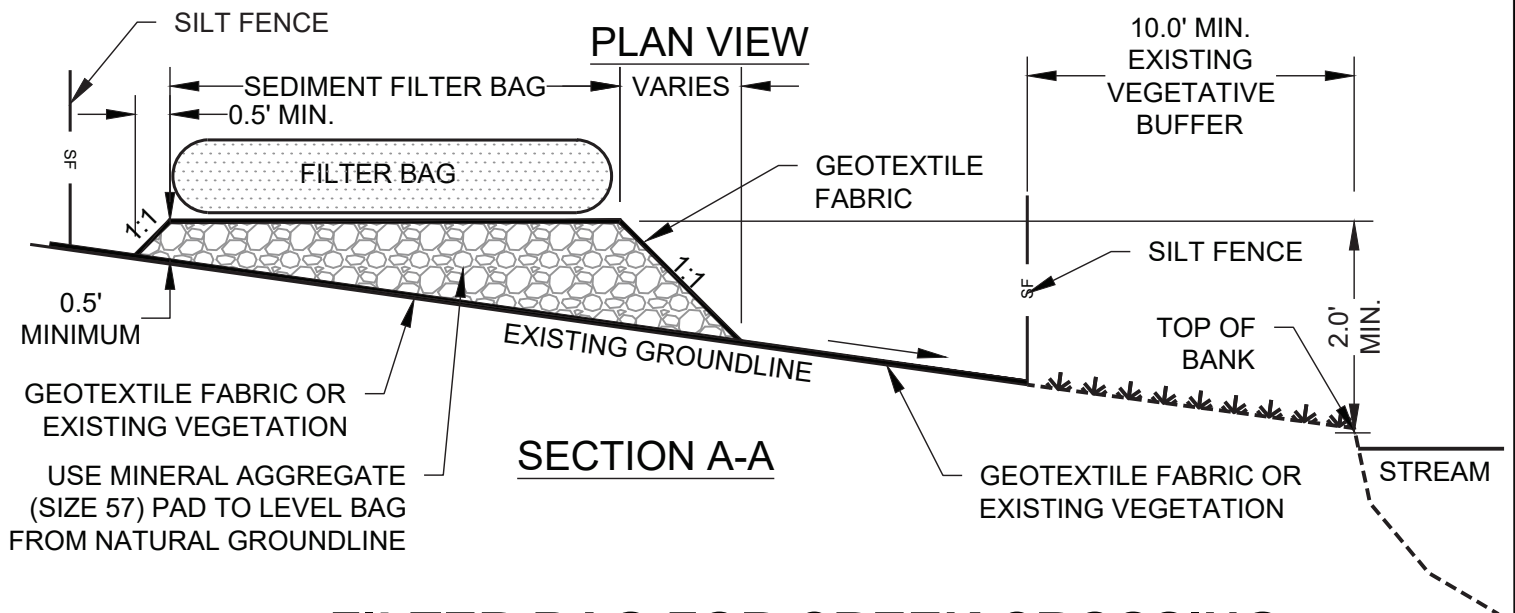
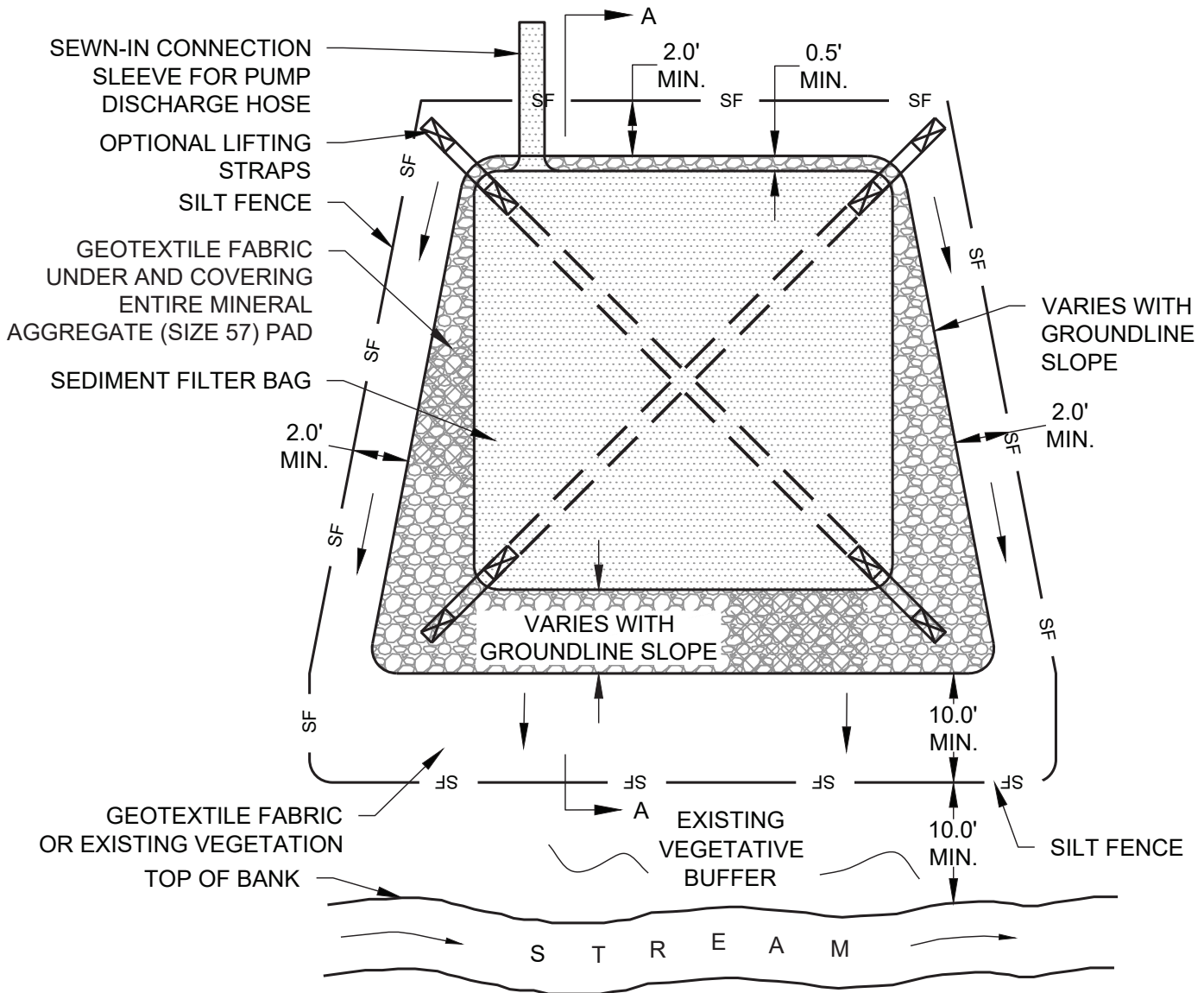

FILTER BAG FOR CREEK CROSSING

NOT TO SCALE

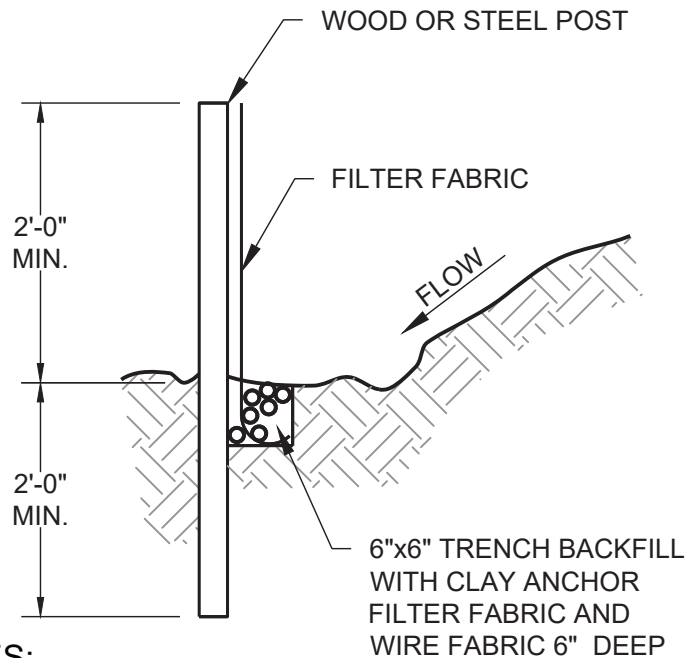

NOTES:

1. FILTER FABRIC FENCE TO BE PLACED PRIOR TO START OF ROUGH GRADING.
2. STEEL POSTS SHALL BE APPROVED BY OWNER PRIOR TO USE.
3. WOOD POSTS SHALL BE 2"x 2" MIN., OAK OR SIMILAR HARDWOOD.
4. POSTS SHALL BE SPACED AT 6' INTERVALS.
5. FILTER FABRIC SHALL BE SECURELY BOUND TO POSTS WITH EITHER STAPLES OR WIRE TIES.
6. FILTER FABRIC SHALL BE POLYPROPYLENE FABRIC WITH EQUIVALENT OPENING SIZE (EOS) OF NO.100 SIEVE MIN., NO.40 SIEVE MAX., AS DETERMINED BY CORPS OF ENGINEERS GUIDE SPEC. CW 02215.

TEMPORARY SILT FENCE

NOT TO SCALE

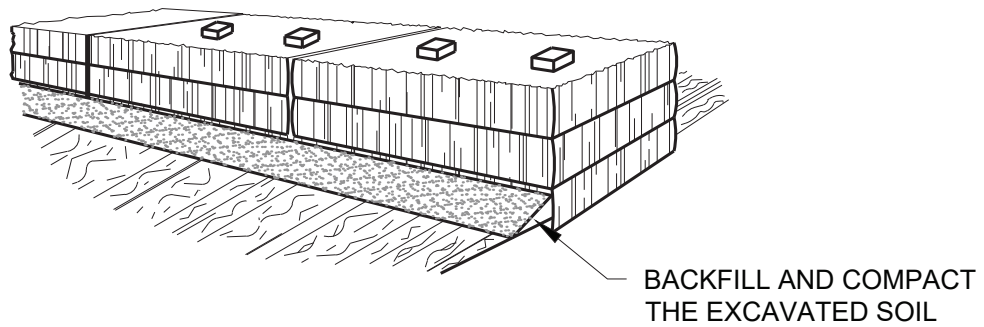
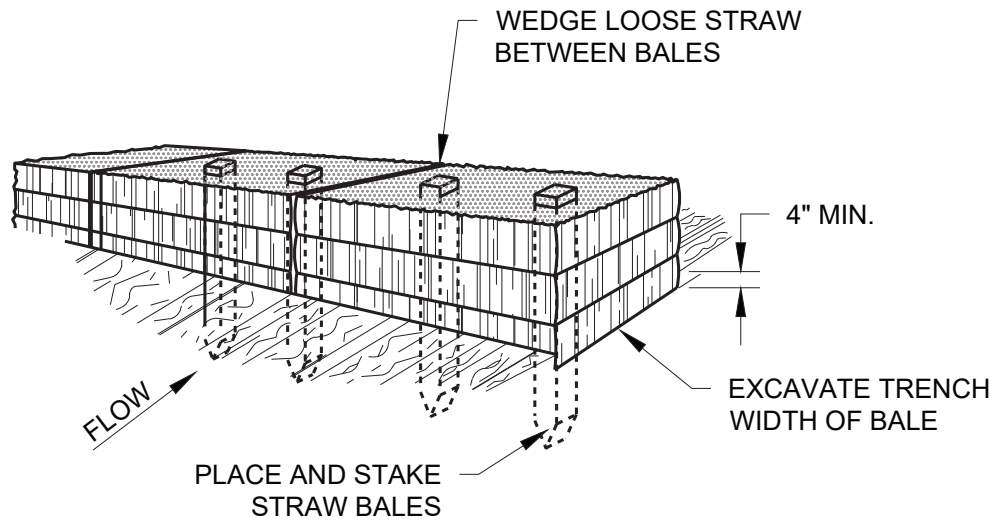

STRAW BALE BARRIER

NOT TO SCALE

DETAIL FOR V DITCH

DETAIL FOR TRAPEZOIDAL DITCH

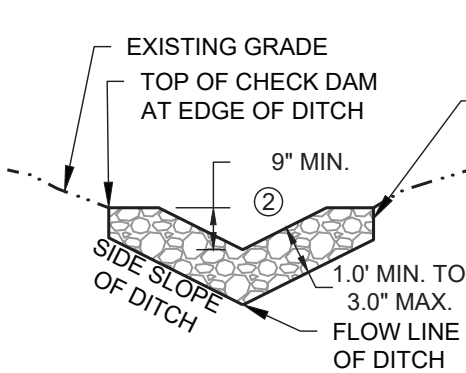
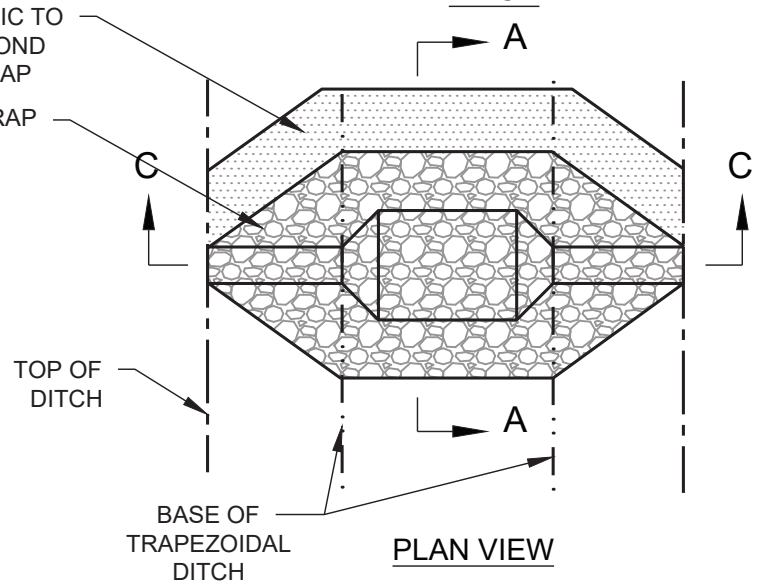
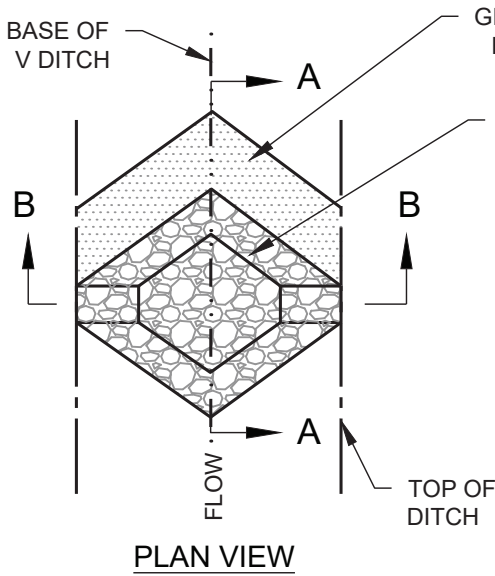

SECTION B-B

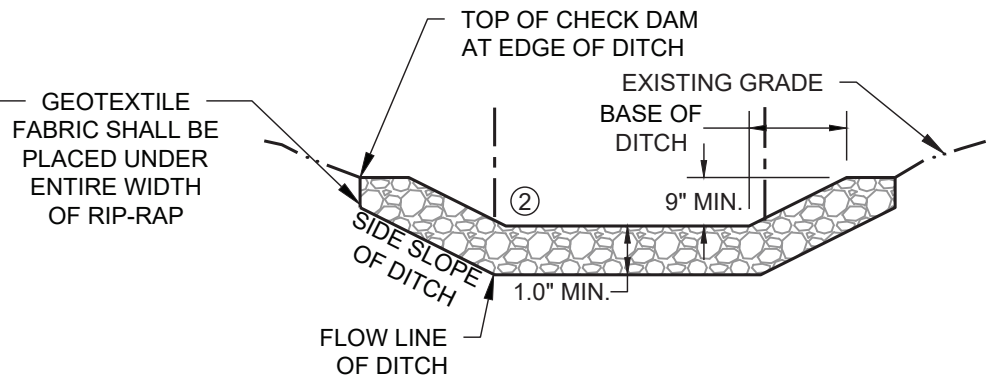

SECTION C-C

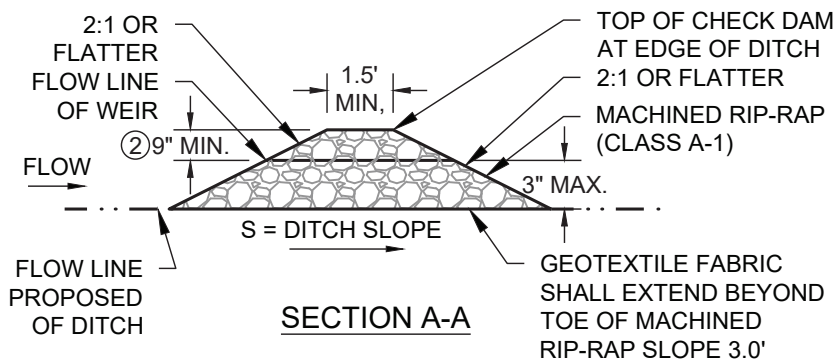

SECTION A-A

NOTES:

- ① FILL LOW AREAS ALONG TOP OF BANK TO PREVENT BACKWATER FROM EXISTING DITCH.
 - ② WEIR FLOW DEPTH BASED UPON 2 YR. / 24 HR. STORM EVENT OR 5 YR. / 24 HR. STORM EVENT.
- L = THE DISTANCE SUCH THAT POINTS (X) AND (Y) ARE OF EQUAL ELEVATION

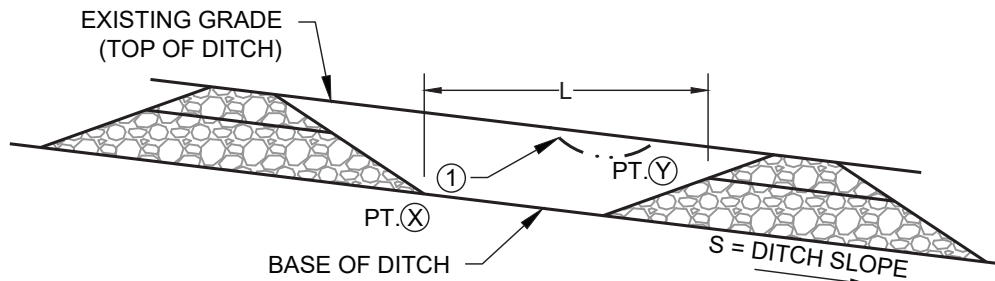

DETAIL FOR SPACING BETWEEN CHECK DAMS

STONE (ROCK) CHECK DAM DETAIL

NOT TO SCALE

5.27W
02/2026

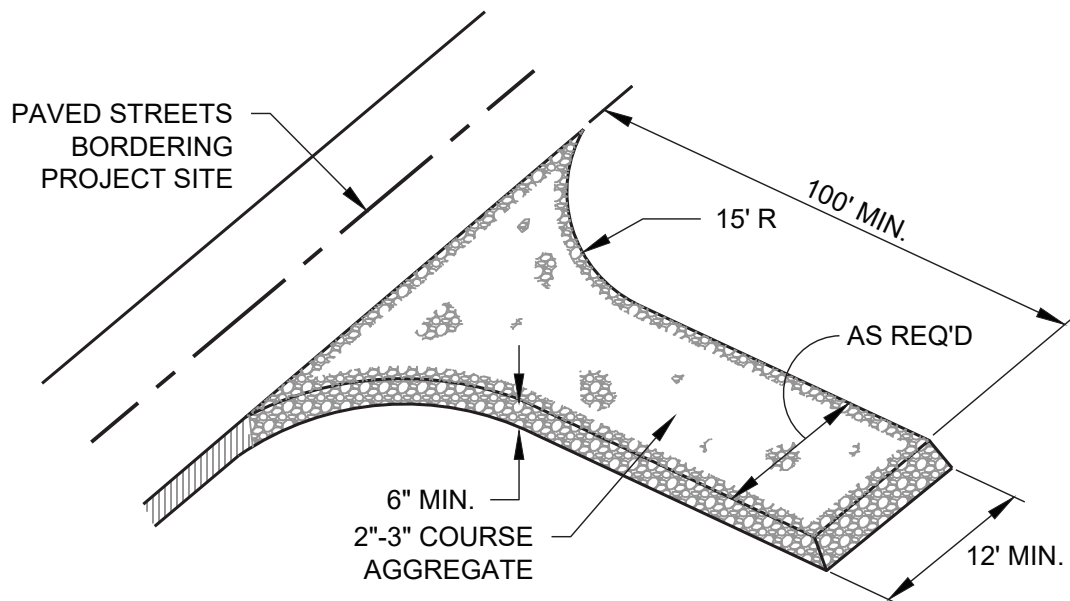

NOTE:

GRAVEL PAD IS REQUIRED TO PROVIDE BUFFER AREA WHERE VEHICLES CAN DROP THEIR MUD AND SEDIMENT TO AVOID TRANSPORTING IT ONTO PAVED STREETS, TO CONTROL EROSION FROM SURFACE RUNOFF, AND TO HELP CONTROL DUST.

TEMPORARY CONSTRUCTION ENTRANCE

NOT TO SCALE

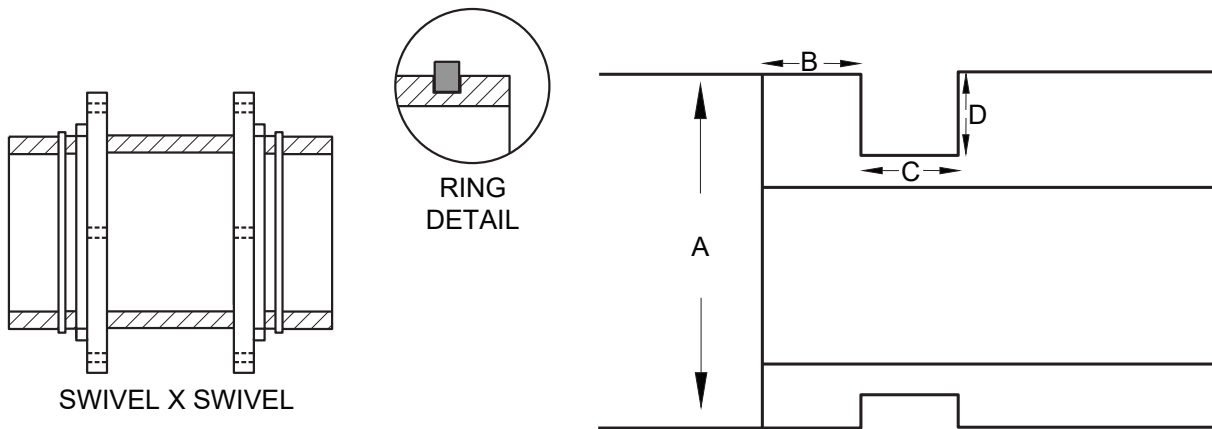

	A	B	C	D	SNAP RING
SIZE	(NOM. O.D.)	(CUTBACK)	(WIDTH)	(DEPTH)	WIDTH
TOLERANCE	(+ / -)	(+ / -)	(+ .015)	(+ / -)	(+ / -)
3"	4.02	2"	.250	.130	.2344
4"	4.86	2"	.250	.130	.2344
6"	6.96	2"	.250	.130	.2344
8"	9.11	2"	.250	.130	.2344
10"	11.16	2"	.250	.130	.2344
12"	13.26	2"	.250	.130	.2344
14"	15.35	2 1/2"	.375	.1875	.3595
16"	17.45	2 1/2"	.375	.1875	.3595
18"	19.55	2 1/2"	.375	.1875	.3595

NOTES:

TOLERANCE ON LENGTH OF PIPE SHALL BE 0.25".
 ABOVE MATERIALS SHALL MEET ALL APPLICABLE SECTIONS OF A.N.S.I. A21.10, A21.15, A21.50, A21.51, B2.1, B16.1/ A.W.W.A. C110, C115, C150, C151, AND ALL REVISIONS THERETO.
 ANCHOR PIPE SHALL BE MADE OF DUCTILE IRON PIPE CLASS 53.
 3" – 24" MJ ANCHOR COUPLINGS ARE PRESSURE RATED AT 350 PSI.
 LINING SHALL BE IN ACCORDANCE WITH A.N.S.I. A21.4., AWWA C104
 MECHANICAL JOINT GLAND A.N.S.I. / A.W.W.A. A21.10 / C110, A21.53 / C153.
 AVAILABLE IN ALL SIZES AND LENGTHS – AS REQUIRED.
 MJ ANCHOR COUPLINGS BY BLUE PATRIOT FAB OR APPROVED EQUAL MAY BE USED IN LIEU OF FOSTER ADAPTERS ON LONG LAY LENGTHS.

MJ ANCHOR COUPLINGS - LENGTH AS NEEDED

NOT TO SCALE